

## User's Manual





# *MGP 462* *MGP 462D*

## Multi-Graphic Processor

# Precautions

## Safety Instructions • English

 This symbol is intended to alert the user of important operating and maintenance (servicing) instructions in the literature provided with the equipment.

 This symbol is intended to alert the user of the presence of uninsulated dangerous voltage within the product's enclosure that may present a risk of electric shock.

### Caution

**Read Instructions** • Read and understand all safety and operating instructions before using the equipment.

**Retain Instructions** • The safety instructions should be kept for future reference.

**Follow Warnings** • Follow all warnings and instructions marked on the equipment or in the user information.

**Avoid Attachments** • Do not use tools or attachments that are not recommended by the equipment manufacturer because they may be hazardous.

## Consignes de Sécurité • Français

 Ce symbole sert à avertir l'utilisateur que la documentation fournie avec le matériel contient des instructions importantes concernant l'exploitation et la maintenance (réparation).

 Ce symbole sert à avertir l'utilisateur de la présence dans le boîtier de l'appareil de tensions dangereuses non isolées posant des risques d'électrocution.

### Attention

**Lire les instructions** • Prendre connaissance de toutes les consignes de sécurité et d'exploitation avant d'utiliser le matériel.

**Conservier les instructions** • Ranger les consignes de sécurité afin de pouvoir les consulter à l'avenir.

**Respecter les avertissements** • Observer tous les avertissements et consignes marqués sur le matériel ou présentés dans la documentation utilisateur.

**Eviter les pièces de fixation** • Ne pas utiliser de pièces de fixation ni d'outils non recommandés par le fabricant du matériel car cela risquerait de poser certains dangers.

## Sicherheitsanleitungen • Deutsch

 Dieses Symbol soll dem Benutzer in der im Lieferumfang enthaltenen Dokumentation besonders wichtige Hinweise zur Bedienung und Wartung (Instandhaltung) geben.

 Dieses Symbol soll den Benutzer darauf aufmerksam machen, daß im Inneren des Gehäuses dieses Produktes gefährliche Spannungen, die nicht isoliert sind und die einen elektrischen Schock verursachen können, herrschen.

### Achtung

**Lesen der Anleitungen** • Bevor Sie das Gerät zum ersten Mal verwenden, sollten Sie alle Sicherheits- und Bedienungsanleitungen genau durchlesen und verstehen.

**Aufbewahren der Anleitungen** • Die Hinweise zur elektrischen Sicherheit des Produktes sollten Sie aufbewahren, damit Sie im Bedarfsfall darauf zurückgreifen können.

**Befolgen der Warnhinweise** • Befolgen Sie alle Warnhinweise und Anleitungen auf dem Gerät oder in der Benutzerdokumentation.

**Keine Zusatzgeräte** • Verwenden Sie keine Werkzeuge oder Zusatzgeräte, die nicht ausdrücklich vom Hersteller empfohlen wurden, da diese eine Gefahrenquelle darstellen können.

## Instrucciones de seguridad • Español

 Este símbolo se utiliza para advertir al usuario sobre instrucciones importantes de operación y mantenimiento (o cambio de partes) que se desean destacar en el contenido de la documentación suministrada con los equipos.

 Este símbolo se utiliza para advertir al usuario sobre la presencia de elementos con voltaje peligroso sin protección aislante, que puedan encontrarse dentro de la caja o alojamiento del producto, y que puedan representar riesgo de electrocución.

### Precaución

**Leer las instrucciones** • Leer y analizar todas las instrucciones de operación y seguridad, antes de usar el equipo.

**Conservar las instrucciones** • Conservar las instrucciones de seguridad para futura consulta.

**Obedecer las advertencias** • Todas las advertencias e instrucciones marcadas en el equipo o en la documentación del usuario, deben ser obedecidas.

**Evitar el uso de accesorios** • No usar herramientas o accesorios que no sean específicamente recomendados por el fabricante, ya que podrían implicar riesgos.

## 安全须知 • 中文

 这个符号提示用户该设备用户手册中有重要的操作和维护说明。

 这个符号警告用户该设备机壳内有露的危险电压，有触电危险。

### 注意

**阅读说明书** • 用户使用该设备前必须阅读并理解所有安全和使用说明。

**保存说明书** • 用户应保存安全说明书以备将来使用。

**遵守警告** • 用户应遵守产品和用户指南上的所有安全和操作说明。

**避免追加** • 不要使用该产品的厂商没有推荐的工具或追加设备，以避免危险。

## Warning

**Power sources** • This equipment should be operated only from the power source indicated on the product. This equipment is intended to be used with a main power system with a grounded (neutral) conductor. The third (grounding) pin is a safety feature, do not attempt to bypass or disable it.

**Power disconnection** • To remove power from the equipment safely, remove all power cords from the rear of the equipment, or the desktop power module (if detachable), or from the power source receptacle (wall plug).

**Power cord protection** • Power cords should be routed so that they are not likely to be stepped on or pinched by items placed upon or against them.

**Servicing** • Refer all servicing to qualified service personnel. There are no user-serviceable parts inside. To prevent the risk of shock, do not attempt to service this equipment yourself because opening or removing covers may expose you to dangerous voltage or other hazards.

**Slots and openings** • If the equipment has slots or holes in the enclosure, these are provided to prevent overheating of sensitive components inside. These openings must never be blocked by other objects.

**Lithium battery** • There is a danger of explosion if battery is incorrectly replaced. Replace it only with the same or equivalent type recommended by the manufacturer. Dispose of used batteries according to the manufacturer's instructions.

## Avertissement

**Alimentations** • Ne faire fonctionner ce matériel qu'avec la source d'alimentation indiquée sur l'appareil. Ce matériel doit être utilisé avec une alimentation principale comportant un fil de terre (neutre). Le troisième cordon (de mise à la terre) constitue un dispositif de sécurité : n'essayez pas de la contourner ni de la désactiver.

**Déconnexion de l'alimentation** • Pour mettre le matériel hors tension sans danger, déconnectez tous les cordons d'alimentation de l'arrière de l'appareil ou du module d'alimentation de bureau (s'il est amovible) ou encore de la prise secteur.

**Protection du cordon d'alimentation** • Acheminer les cordons d'alimentation de manière à ce que personne ne risque de marcher dessus et à ce qu'ils ne soient pas écrasés ou pincés par des objets.

**Réparation-maintenance** • Faire exécuter toutes les interventions de réparation-maintenance par un technicien qualifié. Aucun des éléments internes ne peut être réparé par l'utilisateur. Afin d'éviter tout danger d'électrocution, l'utilisateur ne doit pas essayer de procéder lui-même à ces opérations car l'ouverture ou le retrait des couvercles risquent de l'exposer à de hautes tensions et autres dangers.

**Fentes et orifices** • Si le boîtier de l'appareil comporte des fentes ou des orifices, ceux-ci servent à empêcher les composants internes sensibles de surchauffer. Ces ouvertures ne doivent jamais être bloquées par des objets.

**Lithium Batterie** • Il a danger d'explosion s'il y a remplacement incorrect de la batterie. Remplacer uniquement avec une batterie du même type ou d'un type équivalent recommandée par le constructeur. Mettre au rebut les batteries usagées conformément aux instructions du fabricant.

## Vorsicht

**Stromquellen** • Dieses Gerät sollte nur über die auf dem Produkt angegebene Stromquelle betrieben werden. Dieses Gerät wurde für eine Verwendung mit einer Hauptstromleitung mit einem geerdeten (neutralen) Leiter konzipiert. Der dritte Kontakt ist für einen Erdanschluß, und stellt eine Sicherheitsfunktion dar. Diese sollte nicht umgangen oder außer Betrieb gesetzt werden.

**Stromunterbrechung** • Um das Gerät auf sichere Weise vom Netz zu trennen, sollten Sie alle Netzkabel aus der Rückseite des Gerätes, aus der externen Stromversorgung (falls dies möglich ist) oder aus der Wandsteckdose ziehen.

**Schutz des Netzkabels** • Netzkabel sollten stets so verlegt werden, daß sie nicht im Weg liegen und niemand darauf treten kann oder Objekte darauf- oder unmittelbar dagegen gestellt werden können.

**Wartung** • Alle Wartungsmaßnahmen sollten nur von qualifiziertem Servicepersonal durchgeführt werden. Die internen Komponenten des Gerätes sind wartungsfrei. Zur Vermeidung eines elektrischen Schocks versuchen Sie in keinem Fall, dieses Gerät selbst öffnen, da beim Entfernen der Abdeckungen die Gefahr eines elektrischen Schlags und/oder andere Gefahren bestehen.

**Schlitze und Öffnungen** • Wenn das Gerät Schlitze oder Löcher im Gehäuse aufweist, dienen diese zur Vermeidung einer Überhitzung der empfindlichen Teile im Inneren. Diese Öffnungen dürfen niemals von anderen Objekten blockiert werden.

**Lithium-Batterie** • Explosionsgefahr, falls die Batterie nicht richtig ersetzt wird. Ersetzen Sie verbrauchte Batterien nur durch den gleichen oder einen vergleichbaren Batterietyp, der auch vom Hersteller empfohlen wird. Entsorgen Sie verbrauchte Batterien bitte gemäß den Herstelleranweisungen.

## Advertencia

**Alimentación eléctrica** • Este equipo debe conectarse únicamente a la fuente/tipo de alimentación eléctrica indicada en el mismo. La alimentación eléctrica de este equipo debe provenir de un sistema de distribución general con conductor neutro a tierra. La tercera pata (puesta a tierra) es una medida de seguridad, no puentearia ni eliminarla.

**Desconexión de alimentación eléctrica** • Para desconectar con seguridad la acometida de alimentación eléctrica al equipo, desenchar todos los cables de alimentación en el panel trasero del equipo, o desenchar el módulo de alimentación (si fuera independiente), o desenchar el cable del receptáculo de la pared.

**Protección del cable de alimentación** • Los cables de alimentación eléctrica se deben instalar en lugares donde no sean pisados ni apretados por objetos que se puedan apoyar sobre ellos.

**Reparaciones/mantenimiento** • Solicitar siempre los servicios técnicos de personal calificado. En el interior no hay partes a las que el usuario deba acceder. Para evitar riesgo de electrocución, no intentar personalmente la reparación/mantenimiento de este equipo, ya que al abrir o extraer las tapas puede quedar expuesto a voltajes peligrosos u otros riesgos.

**Ranuras y aberturas** • Si el equipo posee ranuras o orificios en su caja/alojamiento, es para evitar el sobrecalentamiento de componentes internos sensibles. Estas aberturas nunca se deben obstruir con otros objetos.

**Batería de litio** • Existe riesgo de explosión si esta batería se coloca en la posición incorrecta. Cambiar esta batería únicamente con el mismo tipo (o su equivalente) recomendado por el fabricante. Desachar las baterías usadas siguiendo las instrucciones del fabricante.

## 警告

**电源** • 该设备只能使用产品上标明的电源。设备必须使用有地线的供电系统供电。第三条线(地线)是安全设施,不能不用或跳过。

**拔掉电源** • 为安全地从设备拔掉电源,请拔掉所有设备后或桌面电源的电源线,或任何接到市电系统的电源线。

**电源线保护** • 妥善布线,避免被踩踏,或重物挤压。

**维护** • 所有维修必须由认证的维修人员进行。设备内部没有用户可以更换的零件。为避免出现触电危险,不要自己试图打开设备盖子维修该设备。

**通风孔** • 有些设备机壳上有通风槽或孔,它们是用来防止机内敏感元件过热。不要用任何东西挡住通风孔。

**锂电池** • 不正确的更换电池会有爆炸的危险。必须使用与厂家推荐的相同或相近型号的电池。按照生产厂的建议处理废弃电池。

# Quick Start — MGP 462

## Installation

### Step 1

Install the four rubber feet on the bottom of the MGP 462, or mount the unit using the supplied rack mounting brackets.

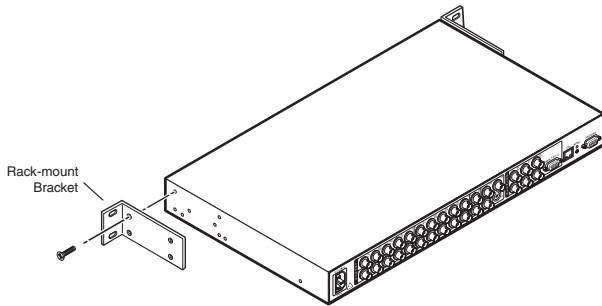

### Rack mounting the MGP 462

### Step 2

Turn off power to the input and output devices, and remove the power cords from them.

### Step 3

Attach the input devices to the MGP 462. The inputs can accept the following signal types:

**Inputs 1, 2, 3, 4** — RGB, component video, S-video, or composite video

**Inputs 3 and 4** — Component video, S-video, or composite video

**Input 5** — S-video or composite video

**Input 6** — S-video (4-pin mini DIN connector), composite video (VID BNC connector), or SDI (MGP 462D model only)

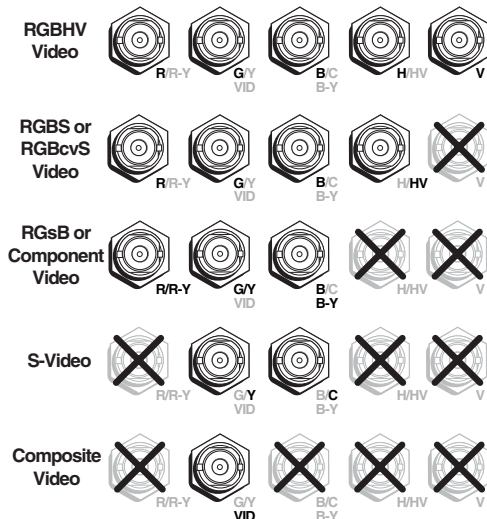

### Input connectors

### Step 4

Attach an output device to the RGBHV/YUV BNC connectors (shown below) and/or to the 15-pin HD output connector (shown at right).

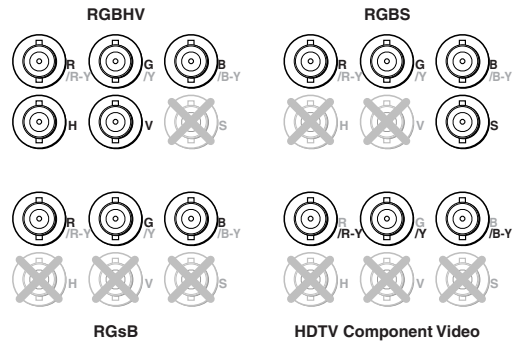

### BNC output connectors

### Step 5

Plug the MGP 462, input devices, and output devices into a grounded AC source, and power on the input and output devices.

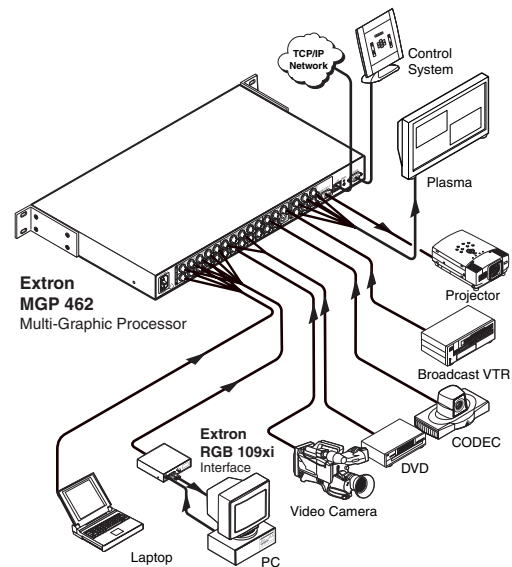

### MGP 462 connection diagram

### Step 6

Use the LCD menu screens and Adjust knobs to configure the MGP 462 and adjust the picture controls (see the following section, *Configuring and Adjusting the MGP 462*). See chapter 2 for installation instructions, chapter 3 for front panel operation information, chapter 4 for control via the RS-232/422 interface, and chapter 5 for Ethernet control.

## Quick Start — MGP 462, cont'd

### Getting Started

After you have installed and connected the MGP 462, follow these steps to configure and adjust it to get it ready for use.

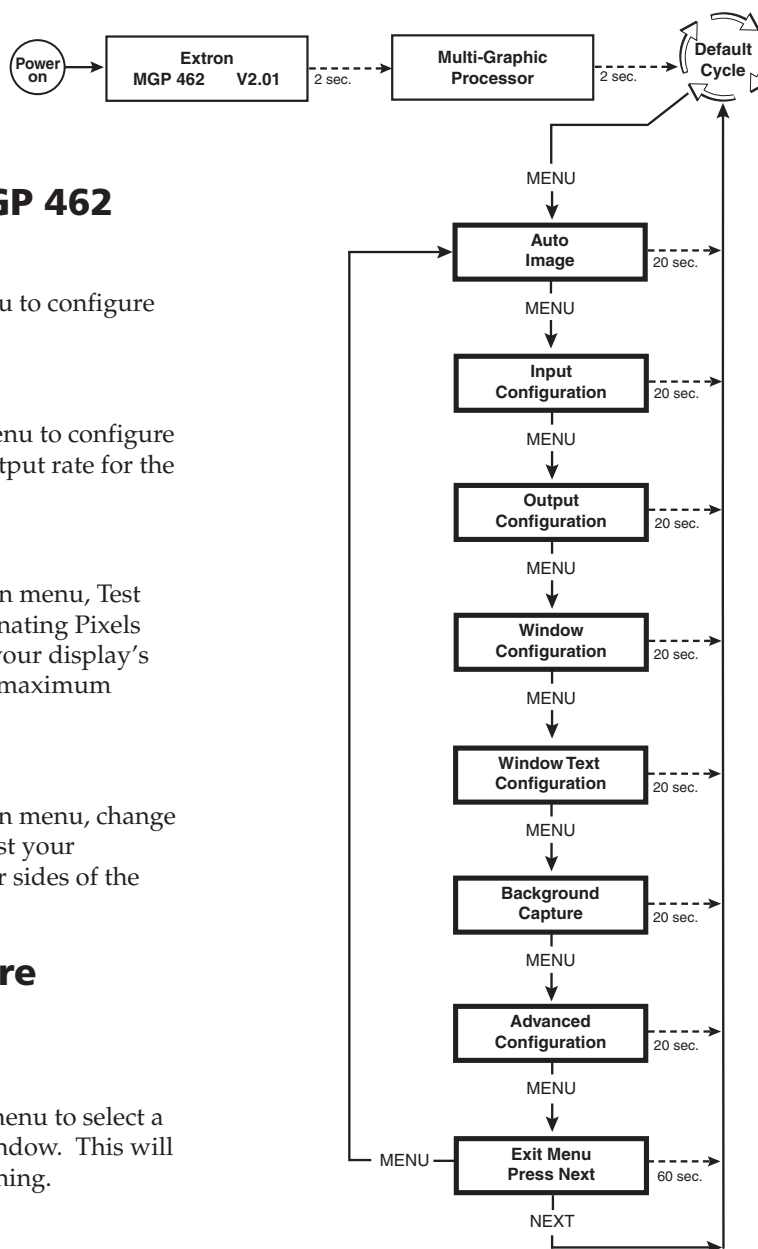

#### Main Menu flow

- c. Press the Window/Image Size button **once**, and turn the Adjust knobs to the **right** until they stop. The window size setting displays the same resolution as the output.
- d. Repeat steps a through c for the remaining window.

**NOTE** With both windows at full screen size, you must mute window 2 in order to set window 1, and vice versa.

### Configuring the MGP 462

#### Step 1

Use the Input Configuration menu to configure each of the six inputs.

#### Step 2

Use the Output Configuration menu to configure the output signal type and the output rate for the desired resolution.

#### Step 3

From the Advanced Configuration menu, Test Pattern submenu, select the Alternating Pixels (Alt. Pixels) test pattern. Adjust your display's total pixel and phase settings for maximum picture quality.

#### Step 4

From the Advanced Configuration menu, change the test pattern to Crop, and adjust your display's positioning until all four sides of the crop pattern are visible.

### Adjusting the picture controls

#### Step 5

Use the Window Configuration menu to select a window border color for each window. This will aid in window sizing and positioning.

#### Step 6

Select input 1 for both windows.

#### Step 7

Adjust windows 1 and 2 to full screen:

- a. Press the Window 1 or the Window 2 button to select the window to adjust.
- b. Press the Window/Image Position button **once**, and turn the Adjust knobs until both the H and V values = 0000.



## Quick Start — MGP 462, cont'd

### Step 8

For each input, size and position the image within both window 1 and window 2.

- a. Press one of the six input buttons in the top row (for window 1) or the bottom row (for window 2).
- b. Press the window button that corresponds with the input button that you pressed (e.g., if you pressed the **top** input 3 button in step 1, press the **Window 1** button).
- c. Press the Window/Image Size or the Window/Image Position button **twice**. The LCD window displays the number of the input whose image you are sizing or positioning.
- d. Rotate the Adjust knobs until the H and V values represent the image dimensions or position coordinates you want for the selected input.
- e. Repeat steps c and d as needed to refine the size and position adjustments for the selected input.
- f. Repeat steps a through e for the same input in the other window.
- g. Repeat steps a through f for each remaining input.

### Auto Image

Auto Image provides a quick way to size an input to fit the current window size. To auto-size an image, follow these steps:

- a. Press the numbered button for the input that you want to auto-size.
- b. Press the Menu button once to select the Auto Image menu.
- c. Press the Next button to display the Auto Image selection screen in the LCD window.
- d. Turn either Adjust knob to select window 1 or 2.
- e. Press the Next button again to implement your selection.

### Step 9

Use the Input Configuration menu to make any desired advanced adjustments, including Horizontal and Vertical Start, Pixel Phase, Total Pixel, Active Pixel, and Active Lines. See chapter 3, *Operation*, for information on these adjustments.

### Step 10

When finished adjusting the desired picture controls, save your configuration as a window preset:

- a. Press the Preset Recall/Save button and **hold** it for at least 2 seconds.
- b. Use either Adjust knob to select the preset number to which you want to save this configuration.
- c. Press the Enter button.

### Step 11

You can now size and position windows for each of your applications and save each one to any one of the remaining 24 window preset locations for easy recall of window settings.

You can also save presets using the MGP 462 Web pages (see chapter 5) or the MGP 462 Windows®-based configuration software (see *Windows®-based Configuration Software* in chapter 4 for instructions on accessing the software and its online Help).

## Quick Start — MGP 462, cont'd

---

# Table of Contents

---

<b>Chapter 1 • Introduction</b> .....	1-1
<b>About This Manual</b> .....	1-2
<b>About the MGP 462/462D</b> .....	1-2
<b>Features</b> .....	1-2
<b>Application Diagram</b> .....	1-3
<b>Chapter 2 • Installation</b> .....	2-1
<b>Mounting the MGP 462</b> .....	2-2
Tabletop use .....	2-2
Rack mounting .....	2-2
<b>Connecting the MGP 462</b> .....	2-3
<b>Installing or Replacing Button Labels</b> .....	2-3
<b>Cabling</b> .....	2-4
Input connectors .....	2-5
LAN connector .....	2-5
Configuring the LAN port .....	2-6
Reset button and LED .....	2-6
Remote control connector .....	2-7
Output connectors .....	2-7
Power connector .....	2-7
<b>Chapter 3 • Operation</b> .....	3-1
<b>Front Panel Features</b> .....	3-2
<b>Power-up and Default Cycle</b> .....	3-3
<b>Input Selection</b> .....	3-3
<b>Window Selection Buttons</b> .....	3-4
<b>Menus, Configuration, and Adjustments</b> .....	3-4
Menu system overview .....	3-4
Using the menus .....	3-4
Auto Image menu .....	3-6
Input Configuration menu .....	3-6
Input configuration submenu adjustments .....	3-8
Output Configuration menu .....	3-9
Resolution and Refresh Rate submenu .....	3-10
Output Type submenu .....	3-11
Sync Polarity submenu .....	3-11
Window Configuration menu .....	3-11
Window Priority submenu .....	3-11
Window 1 Border and Window 2 Border submenus .....	3-12
Window Effect submenu .....	3-12
Available effects .....	3-12
Effect Duration submenu .....	3-13

## Table of Contents, cont'd

---

Window Text Configuration menu .....	3-14
Window Text Position submenu .....	3-14
Window Text Size submenu .....	3-14
Windows 1 and 2 Text Color submenus .....	3-14
Windows 1 and 2 Text Background submenus .....	3-15
Windows 1 and 2 Text Border submenus .....	3-15
Windows 1 and 2 Text Label screens .....	3-15
Background Capture menu .....	3-16
Memory space for background files .....	3-16
Saving a background to memory .....	3-16
Recalling a background from memory .....	3-17
Advanced Configuration menu .....	3-17
Background Color submenu .....	3-18
Blue Mode submenu .....	3-18
Test Pattern submenu .....	3-18
Serial Port Mode submenu .....	3-19
Internal Temperature screen .....	3-19
Factory Default submenu .....	3-19
<b>Picture Controls</b> .....	3-19
Adjusting the picture controls .....	3-20
<b>Memory Presets</b> .....	3-21
Window presets .....	3-21
Saving a window preset .....	3-21
Recalling a window preset .....	3-22
Default presets .....	3-23
Input presets .....	3-23
<b>Additional Functions</b> .....	3-24
Freeze mode .....	3-24
Front panel security lockout (executive mode) .....	3-24
Resetting the unit .....	3-24
<b>Chapter 4 • Software Configuration and Control</b> .....	4-1
<b>Setting Up RS-232 / RS-422 Communication</b> .....	4-2
<b>Using Simple Instruction Set (SIS™) Commands</b> .....	4-2
Host-to-MGP communications .....	4-2
MGP-initiated messages .....	4-2
Error responses .....	4-3
Error response references .....	4-3
Telnet and Web communications .....	4-3
Symbol definitions .....	4-5
Command/response table for SIS commands .....	4-8
Command/response table for IP control port commands .....	4-18
<b>Using the Windows®-based Control Software</b> .....	4-31
Installing the software .....	4-31
Starting the control program .....	4-33
<b>Using the Button Label Generator</b> .....	4-34

---

<b>Chapter 5 • Ethernet Configuration and Control</b> .....	5-1
<b>Accessing the Web pages</b> .....	5-2
<b>Viewing System Status</b> .....	5-3
<b>Using the Configuration Pages</b> .....	5-4
System Settings screen .....	5-4
IP Settings fields .....	5-4
Unit Name field .....	5-4
DHCP radio buttons .....	5-4
IP Address field .....	5-5
Gateway IP Address field .....	5-5
Subnet Mask field .....	5-5
MAC Address field .....	5-5
Setting the date and time .....	5-5
Scaler Settings screen .....	5-6
Input configuration .....	5-7
Naming inputs .....	5-7
Selecting the video signal type .....	5-7
Output configuration .....	5-7
Window configuration .....	5-7
Parameters with separate menus for Window 1 and Window 2 .....	5-8
Advanced configuration .....	5-8
Background capture .....	5-8
Passwords screen .....	5-9
Assigning a password .....	5-9
Clearing a password .....	5-9
Email Alerts screen .....	5-10
Setting up SMTP authorization .....	5-11
Firmware Upgrade screen .....	5-11
Determining the current firmware version .....	5-11
Downloading the firmware .....	5-12
Updating the firmware on the MGP 462 .....	5-12
<b>Using the File Management Page</b> .....	5-14
Uploading files .....	5-14
Adding a directory .....	5-14
Other file management activities .....	5-15
<b>Using the Control Pages</b> .....	5-15
User Control screen .....	5-15
Select Window .....	5-15
Input Selection .....	5-15
Window Mute .....	5-16
Executive Mode .....	5-16
Freeze .....	5-16
Film Mode .....	5-16
Picture Controls – Window .....	5-16
Picture Controls – Image .....	5-17



# Table of Contents, cont'd

---

Window Presets screen .....	5-18
Naming a window preset .....	5-19
Saving (creating) a window preset .....	5-19
Recalling a window preset .....	5-19
Input Presets screen .....	5-19
Saving (creating) an input preset .....	5-20
Recalling an input preset .....	5-20
<b>Chapter 6 • Special Application</b> .....	6-1
<b>Connecting the MGP 462 to a Matrix Switcher</b> .....	6-2
Setting up the MGP to work with the switcher .....	6-3
Synchronizing the MGP 462 to the matrix switcher .....	6-4
Additional setup procedures if using a third party control system without the MGP Sync tool .....	6-5
<b>Appendix A • Specifications and Part Numbers</b> .....	A-1
<b>Specifications</b> .....	A-2
<b>Included Parts</b> .....	A-4
<b>Accessories</b> .....	A-4
<b>Appendix B • Installing the SDI Card</b> .....	B-1
<b>Installing a Serial Digital Interface (SDI) Card</b> .....	B-2
<b>Appendix C • Firmware Update Guide</b> .....	C-1
<b>Determining the Firmware Version</b> .....	C-2
Using the LCD display at power-on .....	C-2
Using a Web browser .....	C-2
Using the Windows-based control software .....	C-3
<b>Downloading the Firmware</b> .....	C-4
<b>Updating the Firmware</b> .....	C-4
Updating using the Web pages .....	C-5
Updating using the Windows-based control software .....	C-6

*All trademarks mentioned in this manual are the properties of their respective owners.*

68-840-01 **Rev C**  
08 06



# MGP 462 Multi-Graphic Processor

# Chapter One

## Introduction

About This Manual

About the MGP 462/462D

Features

Application Diagram

# Introduction

---

## About This Manual

This manual discusses how to install, operate, and configure the Extron MGP 462 multi-graphic processor.

Throughout this manual, the terms “MGP,” “multi-graphic processor,” and “processor” are used interchangeably to refer to the same product.

## About the MGP 462/462D

The MGP 462 is a six-input, one-output RGB and video processor that can display two video sources on a single screen in picture-in-picture or picture-by-picture format. It provides switching among inputs, picture controls, and presets.

The MGP accepts RGB video, component video, S-video, and composite video inputs. The MGP 462D is an MGP 462 with an SDI board installed so that input 6 can also accept SDI signals. (See appendix B, *Installing the SDI Card*, for information on installing this board.)

Both versions can be controlled remotely via the RS-232/RS-422 interface using Special Instruction Set (SIS™) commands or via an Ethernet LAN using the MGP 462's embedded Web pages. The MGP 462 Windows®-based control software program can also be used to control the MGP via either the RS-232/422 or the Ethernet connection.

## Features

**Inputs** — The MGP 462 has six video inputs: fully configurable inputs 1 through 4 accept RGB, component, S-video, and composite video signals; input 5 accepts component video, S-video, and composite video; and input 6 accepts S-video and composite video. The MGP 462D model also accepts SDI signals on input 6.

**Output** — The MGP 462 has one scaled RGB or HD YUV output, available on both a 15-pin HD connector and a set of five BNC connectors. This enables two output devices to be connected to the MGP at the same time (both displaying the same image).

**Picture controls** — Picture controls allow you to adjust size, position, brightness, contrast, color, tint, detail, and zoom for each window.

**Window and input presets** — Window presets save sizing, positioning, and priority information. Input presets save input signal type information and picture control settings.

**Window transition effects** — Six types of window transition effects (22 different effects altogether) seamlessly mute and unmute (close and open) the two windows.

**Freeze control** — Freeze control freezes (locks) a window to the current image.

**3:2 pulldown detection for NTSC video and 2:2 film detection for PAL video** — These advanced film mode processing features help maximize image detail and sharpness for video sources that originated from film.

When film is converted to NTSC video, the film frame rate has to be matched to the video frame rate in a process called 3:2 pulldown. Jaggies and other image artifacts can result if conventional deinterlacing techniques are used on film-source video. The MGP 462's advanced film mode processing recognizes signals that originated from film. The MGP then applies video processing algorithms that optimize the conversion of video that was made with the 3:2 pulldown process. This results in richly detailed images with sharply defined lines.

A similar process, 2:2 film detection, is used for PAL film-source video.

**Background image capture, save, and recall** — Background Capture enables you to capture and save the image currently on the output screen. You can then recall the captured image and display it as a background later.

**Auto Image™** — Auto Image automatically sizes, centers, and optimizes the image to the scaled output rate, filling the window.

**Remote control** — The MGP 462 can be operated remotely via the RS-232/422 interface using the Windows-based control software or SIS commands, or via the Ethernet interface using the embedded Web pages.

**Rack mounting** — The 1U high and full rack wide metal enclosure can be rack mounted using the included rack mounting brackets (part #70-077-03).

**Front panel security lockout (executive mode)** — Locks the front panel controls to prevent accidental changes to the unit's settings.

**RGB and video scaling** — All sources are scaled to a single output rate.

## Application Diagram

The application diagram below gives an example of how devices may be connected to the MGP 462.

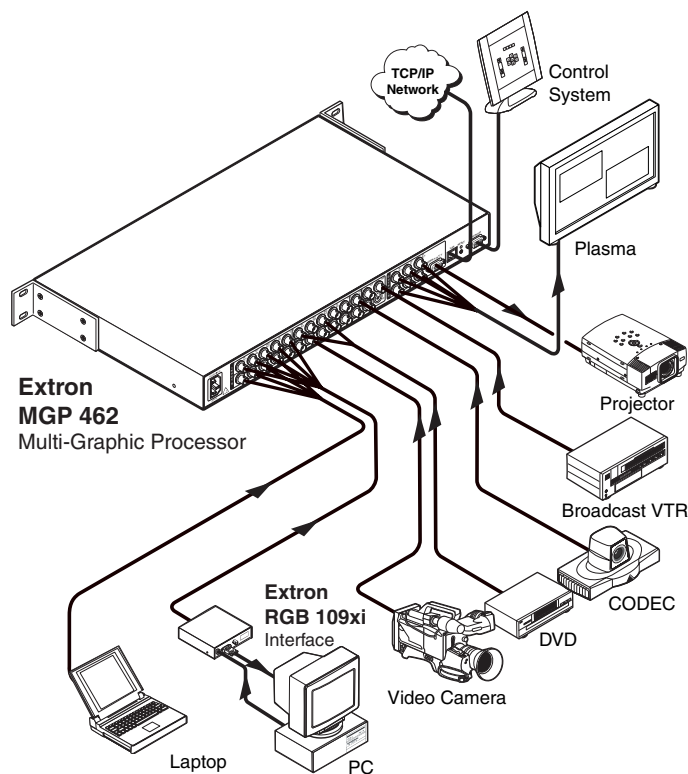

**Connection diagram**

## **Introduction, cont'd**

---





# MGP 462 Multi-Graphic Processor

# Chapter Two

## Installation

Mounting the MGP 462

Connecting the MGP 462

Installing or Replacing Button Labels

Cabling

# Installation

---

## Mounting the MGP 462

### Tabletop use

Four self-adhesive rubber feet are included with the MGP 462. For tabletop use, attach one foot to each corner of the bottom side of the unit and place the MGP in the desired location.

### Rack mounting

The MGP can optionally be mounted in a rack with the supplied MBD 149 rack mounting kit (part #70-077-03). Follow these steps:

1. Attach the mounting brackets to the unit using eight of the machine screws supplied with the mounting kit.

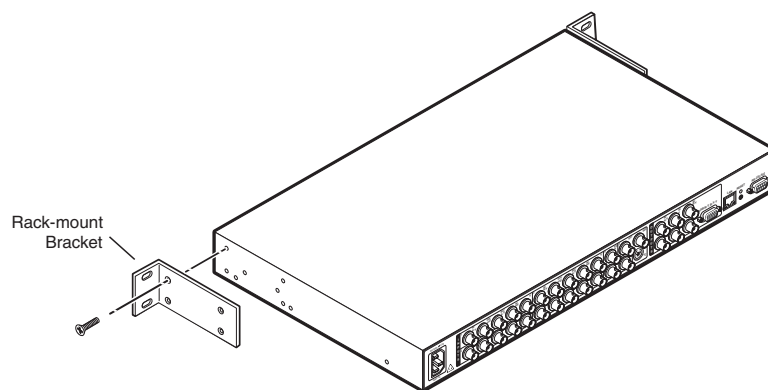

### Attaching the mounting brackets

2. Insert the unit into the rack and align the holes in the mounting brackets with the holes in the rack. Use four of the supplied machine screws to attach the brackets to the rack.

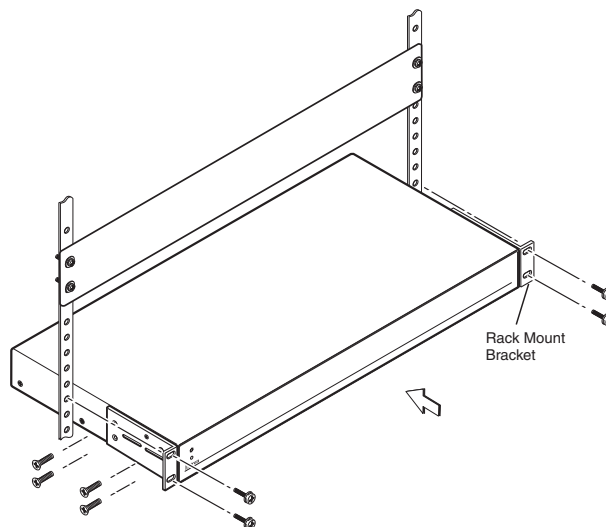

### Rack mounting the MGP 462

---

## Connecting the MGP 462

The MGP 462 processor can be connected to as many as six input devices simultaneously, and two output devices (displaying the same image). Follow the steps below to set up the MGP 462 hardware.

- 1 Disconnect power to the MGP, and turn off all other devices that will be connected.
- 2 If the MGP 462 is to be mounted, see *Mounting the MGP 462*, earlier in this chapter, for the mounting procedure.
- 3 Using the BNC input connectors, attach up to six video input devices to the MGP rear panel.

**NOTE** *S-video and composite video inputs cannot both be connected to input 6 at the same time.*

- 4 Connect one or two output devices to the RGBHV/YUV BNC output connectors and/or to the 15-pin HD connector.
- 5 If the MGP 462 will be connected to a computer or to a host controller for remote control, connect the host's RS-232 cable to the processor's 9-pin RS-232/422 D-sub connector.
- 6 Connect an active LAN Ethernet cable to the RJ-45 port on the rear panel to establish a link to the network.
- 7 Power up the input and output devices, then connect power to the processor.

## Installing or Replacing Button Labels

You may wish to customize your MGP's buttons. The button caps are pre-labeled for your convenience, but you can replace any of these labels with one of the included button labels. You can also create custom labels using the Button-Label Generator software (see *Using the Button Label Generator* in chapter 4, *Software Configuration and Control*), or device such as the Brother P-Touch label maker. Cut the labels so that they are square and ½ inch on each edge.

The button assembly consists of a clear lens cap, the button label, and a white diffuser. (See the illustration on the next page.)

Follow these steps to replace button labels on your MGP:

1. Cut out the desired button label from the provided sheet, or make new labels using the Button-Label Generator or other software and cut them out.
2. Remove the button assembly by inserting a small, flat-bladed screwdriver, such as an Extron Tweaker, between the button's base and the diffuser to gently pry the button assembly off the button plunger.
3. Locate the small corner notch on the lens cap, and slide the screwdriver between the lens cap and the diffuser. (See ① in the illustration on the next page.)
4. Using a rotating motion of the screwdriver, carefully pry the two pieces apart. (See ② in the illustration on the next page.)

# Installation, cont'd

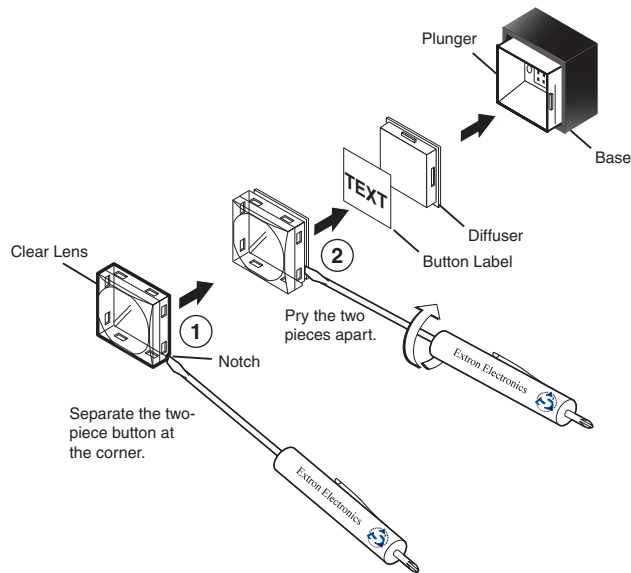

## Replacing a button label

5. Lift out the transparent square label that you want to replace. You may need to use the small screwdriver to gently pry the label out.

**NOTE** Do not pry off the translucent diffuser that is behind the label.

6. Insert one of the new label you created in step 1 into the clear button cap, align the white backing plate with the cap, and firmly snap it into place.
7. Gently, but firmly, press the reassembled button into place on the MGP front panel.
8. Repeat steps 1 through 7 as needed to relabel other buttons.

## Cabling

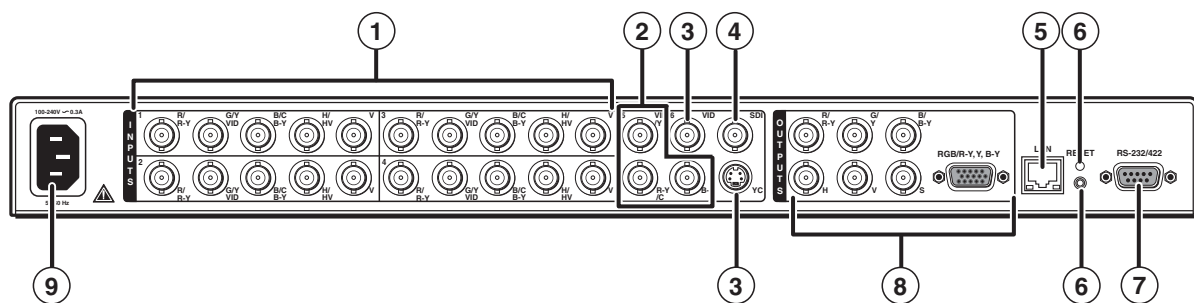

**MGP 462D rear panel** (The MGP 462 is identical except that there is no SDI connector [4].)

## Input connectors

- ① **Inputs 1, 2, 3, and 4** — Plug RGB, component video, S-video, or composite video sources into these BNC connectors as shown in the diagram below.

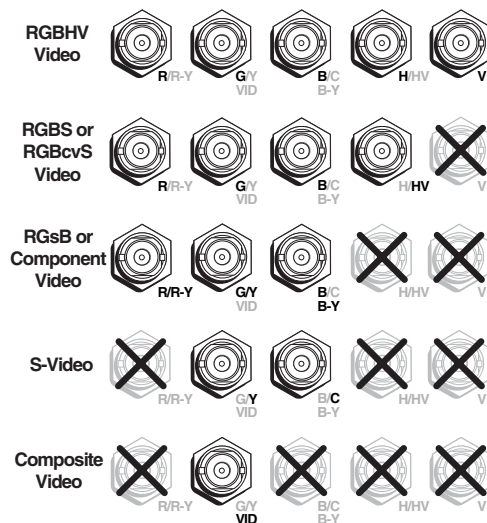

### Connector signal types for inputs 1 through 4

- ② **Input 5** — Plug a component video, S-video, or composite video source into these BNC connectors.

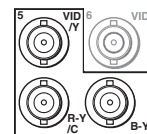

- ③ **Input 6** — Plug an S-video source into the 4-pin mini DIN connector (in bottom row) or a composite video source into the VID BNC connector (in top row).

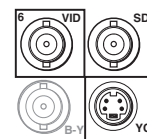

**NOTE** Connecting S-video and composite video devices to input 6 simultaneously causes degraded output display quality.

- ④ **SDI input** — (MGP 462D only) Plug an SDI device into this SDI BNC connector, as an alternative to input 6.

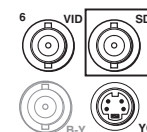

## LAN connector

- ⑤ **LAN connector** — Plug an RJ-45 network cable into this connector to connect the unit to a network (via a switch, hub, or router) or to a single computer. Use a straight-through cable to connect to a network, or a crossover cable to connect directly to a computer.

- For 10Base-T (10 Mbps) networks, use a Cat 3 or better cable.
- For 100 Base-T (max. 155 Mbps) networks, use a Cat 5 cable.

See the illustration on the next page for information on wiring the connector for these two types of cables..

**Activity LED** — This yellow LED blinks to indicate network activity.

**Link LED** — This green LED lights to indicate a good network connection.

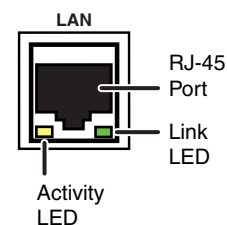



## Installation, cont'd

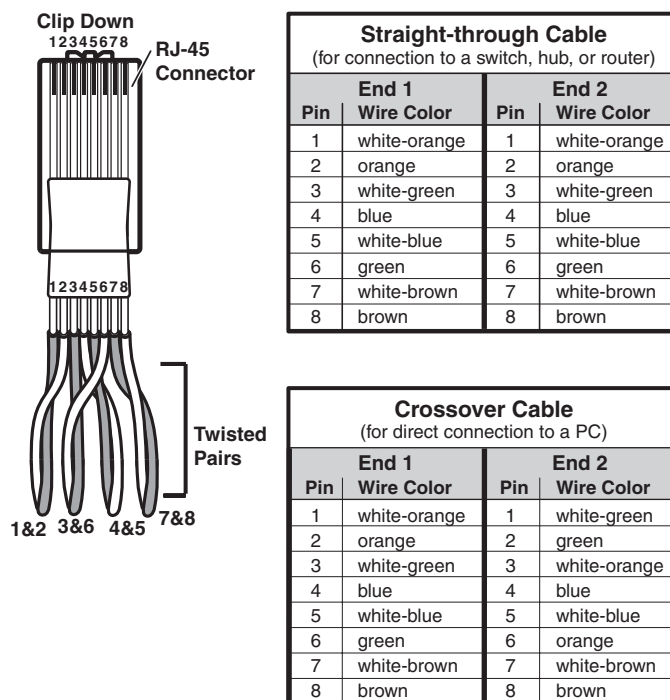

**Pin assignments for LAN connector and cables**

### Configuring the LAN port

You also need to configure the LAN port before using it. This is done with SIS commands. See *Command/Response table for IP control port commands* in chapter 4 for information on these commands.

The LAN port defaults are:

**Processor IP address:** 192.168.254.254

**Gateway IP address:** 0.0.0.0

**Subnet mask:** 255.255.0.0

**DHCP:** off

### Reset button and LED

- ⑥ **Reset button and LED** — Pressing this recessed button causes certain IP functions and Ethernet connection settings to be reset to the factory defaults. The green LED above the button blinks a varying number of times to indicate which reset mode has been entered. See *Resetting the unit* in chapter 3, *Operations*, for information on reset modes.

## Remote control connector

- ⑦ **RS-232/422 connector** — Plug a computer or other RS-232 or RS-422 host device into this female D-sub connector. Wire the connector as shown in the tables below. For more information on controlling the MGP 462 remotely, see chapter 4, *Software Configuration and Control*.

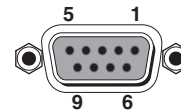

Pin	RS-232 function	Description
1	–	No connection
2	Tx	Transmit data
3	Rx	Receive data
4	–	No connection
5	Gnd	Signal ground
6	–	No connection
7	–	No connection
8	–	No connection
9	–	No connection

Pin	RS-422 function	Description
1	–	No connection
2	Tx-	Transmit ground
3	Rx-	Receive ground
4	–	No connection
5	Gnd	Signal ground
6	–	No connection
7	Rx+	Receive data
8	Tx+	Transmit data
9	–	No connection

### Pin assignments for the RS-232/422 connector

## Output connectors

- ⑧ **Output connectors** — Plug one or two output devices into the 5-BNC and/or the 15-pin HD connector. (When two output devices are attached, they both display the same picture.)

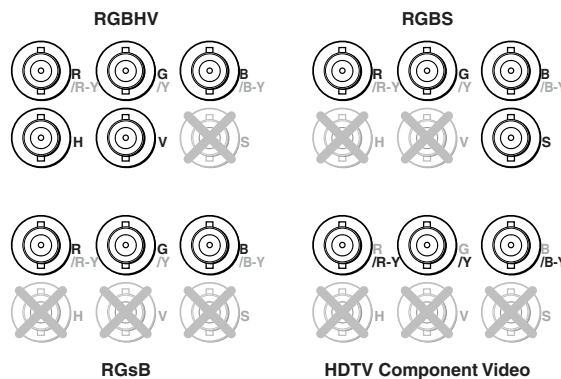

### BNC output connectors

## Power connector

- ⑨ **AC power connector** — Plug the power cord provided with the MGP 462 into this connector to connect the MGP 462 to a 100–250 VAC, 50/60 Hz power source.

# Installation, cont'd

---



# MGP 462 Multi-Graphic Processor

# Chapter Three

## Operation

Front Panel Features

Power-up and Default Cycle

Input Selection

Window Selection Buttons

Menus, Configuration, and Adjustments

Picture Controls

Memory Presets

Additional Functions

# Operation

The MGP 462 can be set up and operated by using:

- The front panel controls
- A computer, a touch screen panel, or any other device that can send and receive serial communications through the RS-232/422 port. Settings can be adjusted through the host computer using Extron's Simple Instruction Set (SIS™) or the Windows-based configuration software.
- A computer or other device using an Ethernet connection and IP protocol (Telnet or a Web browser).

For details on setup and control via RS-232/422, see chapter 4; for Ethernet, see chapter 5.

## Front Panel Features

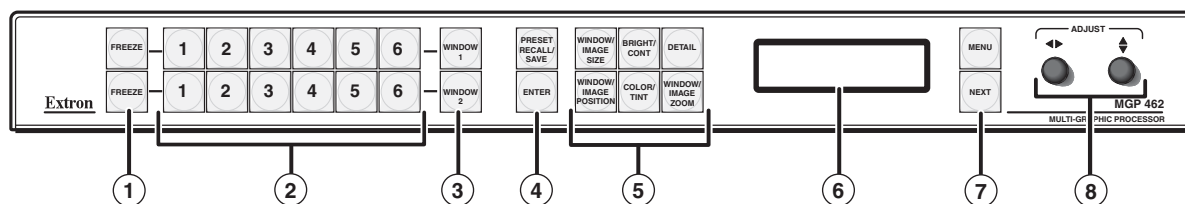

### MGP 462 front panel

- ① **Freeze buttons** — Press these buttons to freeze window 1 (top button) or window 2 (bottom button) to the current image. The Freeze buttons light orange.
- ② **Input selection buttons** — Press these buttons to select inputs for window 1 (top row) and window 2 (bottom row). Six pairs of buttons are provided.  
When an input is selected, pressing the button again *mutes* the input. The input's signal turns off and the window closes. The Window Configuration menu lets you select a window transition effect (e.g., dissolve, curtain, or square wipe) with which the window will open or close (the default effect is *cut*). See *Window Configuration menu*, later in this chapter, for more information. The button flashes while the input remains muted. To unmute the input, press its input button again.
- ③ **Window selection buttons** — Press these buttons to select a window to adjust. (You do not need to press these buttons when freezing the windows or selecting inputs.) While a window is selected, all picture controls are associated with it.
- ④ **Preset buttons** — Press the Preset Recall/Save and Enter buttons to save or recall window presets. See *Window Presets*, later in this chapter, for more information.
- ⑤ **Picture control buttons** — Press these buttons to adjust image size, position, brightness, contrast, color, tint, detail, and zoom. See *Picture Controls*, later in this chapter, for further information.
- ⑥ **LCD screen** — This screen displays messages, menu information, and your selections. See *Menus, Configuration, and Adjustments*, later in this chapter, for more information.
- ⑦ **Menu navigation buttons** — Press Menu to access the MGP 462 menu system and step through the menus. From each menu, press Next to step through its submenus. See *Menus, Configuration, and Adjustments*, later in this chapter, for more information.



- ⑧ **Adjust knobs** — Turn these knobs to adjust picture controls and to scroll through preset memory slots and submenu options. See *Menus, Configuration, and Adjustments*, later in this chapter, for more information.

## Power-up and Default Cycle

When you first plug the MGP 462 into a power source, the LCD screen displays a series of initial messages, followed by the default cycle of screens. These screens continue to display when the menu system is not in use. The following flow diagram shows the order in which these screens appear.

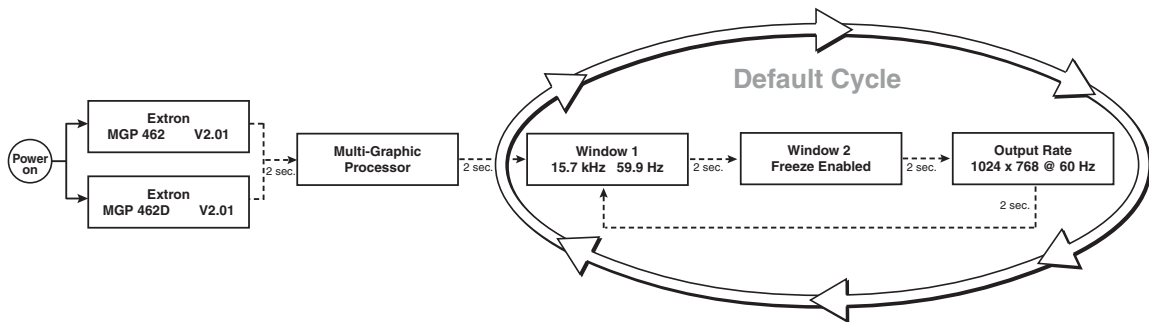

### Default cycle

**NOTE** From any menu or submenu, after 20 seconds of inactivity, the MGP 462 saves all adjustment settings and times out to the default screens.

## Input Selection

The MGP 462 front panel contains two sets of six input buttons, which enable you to select inputs for windows 1 and 2.

- To select an input, press the button containing the number of the input you want to enable.
  - To select the input for window 1, press an input button in the top row. The button you pressed lights green.
  - To select the input for window 2, press an input button in the bottom row. The button you pressed lights red.
- To mute a selected input (turn off its signal and close the window), press its button again. The button blinks continuously, indicating that the input is muted.

When a window is muted or unmuted (opened or closed), the currently selected transition effect (cut, wipe, or dissolve) is used to open or close the window on the screen. See *Window effects submenu* in the *Window Configuration menu* section, later in this chapter, for information on transition effects.

To unmute the input, press its button again. The button's backlight stops flashing and returns to a steady light.

### Window Selection Buttons

The MGP 462 front panel contains two Window buttons, located to the right of the two input 6 buttons. Use these buttons with the picture control buttons to select the window to be adjusted. When you select a picture control, it affects the selected window. (Refer to *Picture Controls*, later in this chapter, for information on the available controls.)

Select window 1 by pressing the top window button, which lights green. To select window 2, press the window button on the bottom, which lights red.

To deselect a window, either press its button again, or press the other window button.

### Menus, Configuration, and Adjustments

The MGP 462's menus enable you to configure the processor. The menu navigation buttons, Menu and Next, are located immediately to the right of the LCD screen. Press these buttons to cycle through the available menu and submenu options.

#### Menu system overview

The MGP 462's menu system consists of a main menu of eight options (menus). Each of these menus has a set of submenus, which enable you to make desired adjustments. (See the diagram on the next page.)

#### Using the menus

To use the menus to configure the system, follow these steps.

**NOTE** *If you do not press a button or turn a knob for 20 seconds, the MGP 462 saves any settings you have made, and the LCD screen reverts to the default cycle.*

1. **Main menu** — To access the Main menu, press the Menu (top) button, located to the right of the LCD screen. The first Main menu option (Auto Image) is displayed on the screen.
2. **Main menu options** — By repeatedly pressing the Menu button, you display additional menus. Press the Menu button repeatedly until the desired menu is displayed.
3. **Submenu options** — When the Main menu item that you want to configure is displayed on the LCD screen, press the Next button (below the Menu button) to cycle through the displayed item's submenu options.
4. **Adjustments** — The third level of menu selections consists of sub-options that are selected by turning the horizontal (◀▶) and vertical (⬆⬇) Adjust knobs. When you have displayed the submenu option that you want to configure, turn the knobs clockwise or counterclockwise to display each available parameter for the selected option.
5. **Implementation** — To save and implement the adjustments you have selected, do one of the following:
  - Press Next to display another submenu option to adjust.
  - Press Menu to return to the Main menu.
  - Do nothing, and wait until the LCD screen returns to the default cycle.Your adjustments remain in effect until you change them.

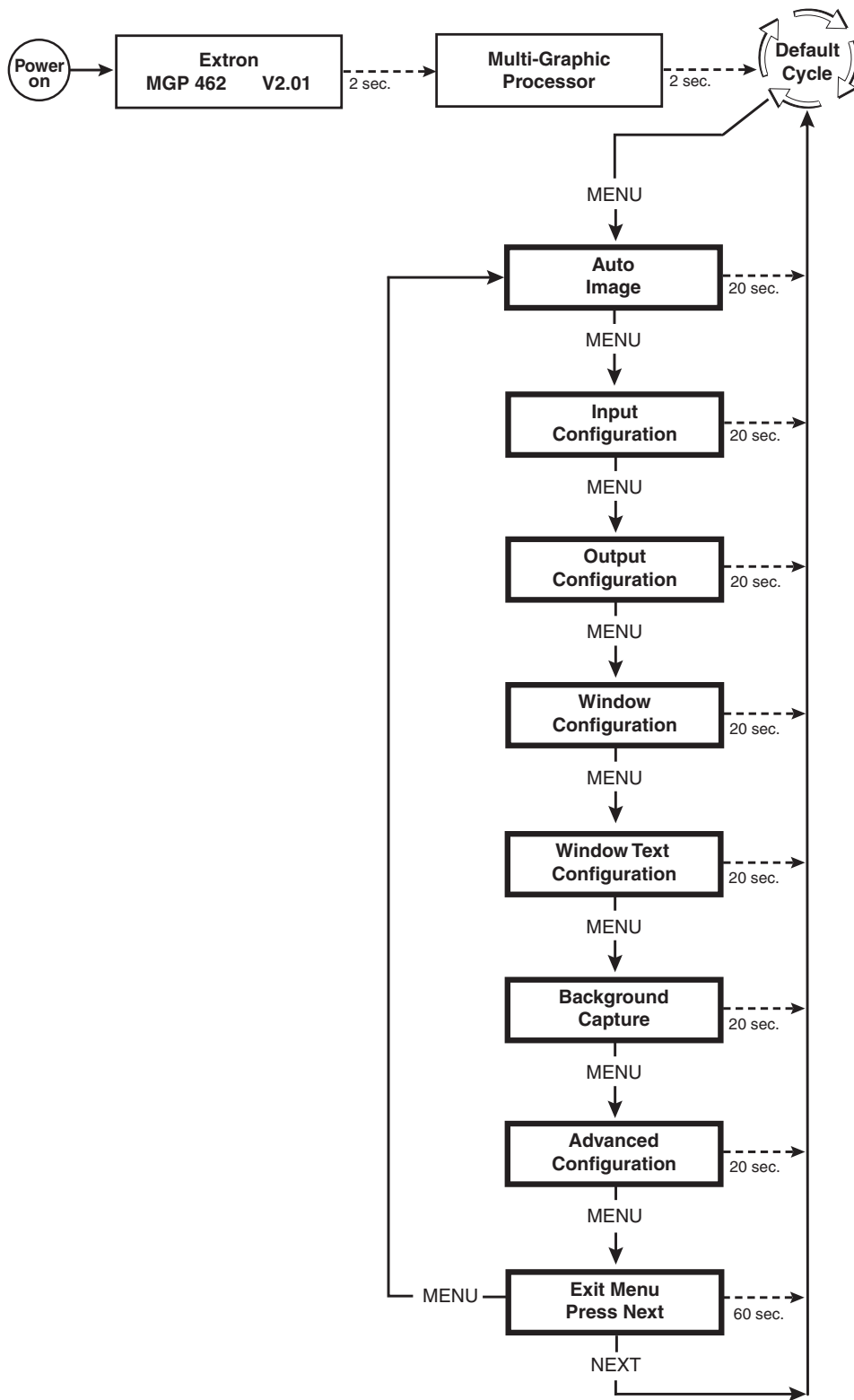

**Main menu flow**

## Operation, cont'd

### Auto Image menu

The Auto Image menu causes the MGP 462 to perform an automatic image adjustment to the selected window. Auto Image measures where the active area starts and stops, and adjusts input sampling accordingly.

When Auto Image is performed, the processor measures the sync frequencies of the incoming video source and sets the active image area, total image area, and sampling frequency according to a table stored on the MGP. If an unknown input is connected to the MGP, the processor measures and estimates the resolution of the incoming video. If the estimate proves not to be accurate, the Auto Image function makes measurements to more accurately set up the input sampling.

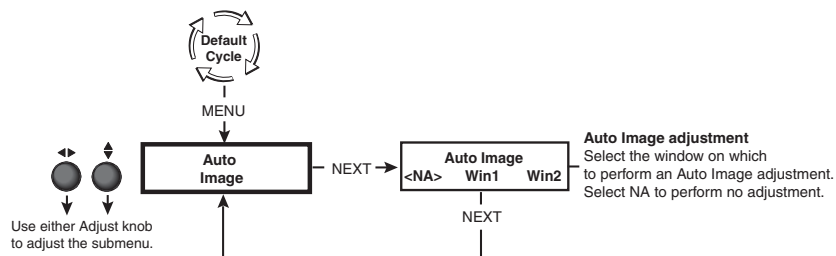

### Auto Image menu flow

To perform an Auto Image adjustment, do the following:

1. Press the Menu button once to display the Auto Image menu.
2. Press the Next button once to display the available option.
3. Rotate the horizontal (◀▶) or vertical (⬆⬇) Adjust knob to select the window for which you want to perform Auto Image.
4. Press Next again to initiate the Auto Image adjustment.
5. If desired, repeat steps 3 and 4 to perform Auto Image in the other window.
6. When finished with Auto Image, do one of the following:
  - Select NA and press Next.
  - Press the Menu button.
  - Do nothing and wait for the menu to time out and return to the default cycle.

### Input Configuration menu

The Input Configuration menu allows you to select the type of video signal that each of the six inputs will pass. You can also select the horizontal and vertical start positions, pixel sampling phase for windows 1 and 2 (except for YUVi, S-video, and composite video), total pixels, active pixels, and active lines for each input. Rotate the horizontal Adjust (◀▶) knob to cycle through the six inputs, and the vertical Adjust knob (⬆⬇) to select settings.

The following diagram shows the submenus of the Input Configuration menu and the adjustments that can be made from them.

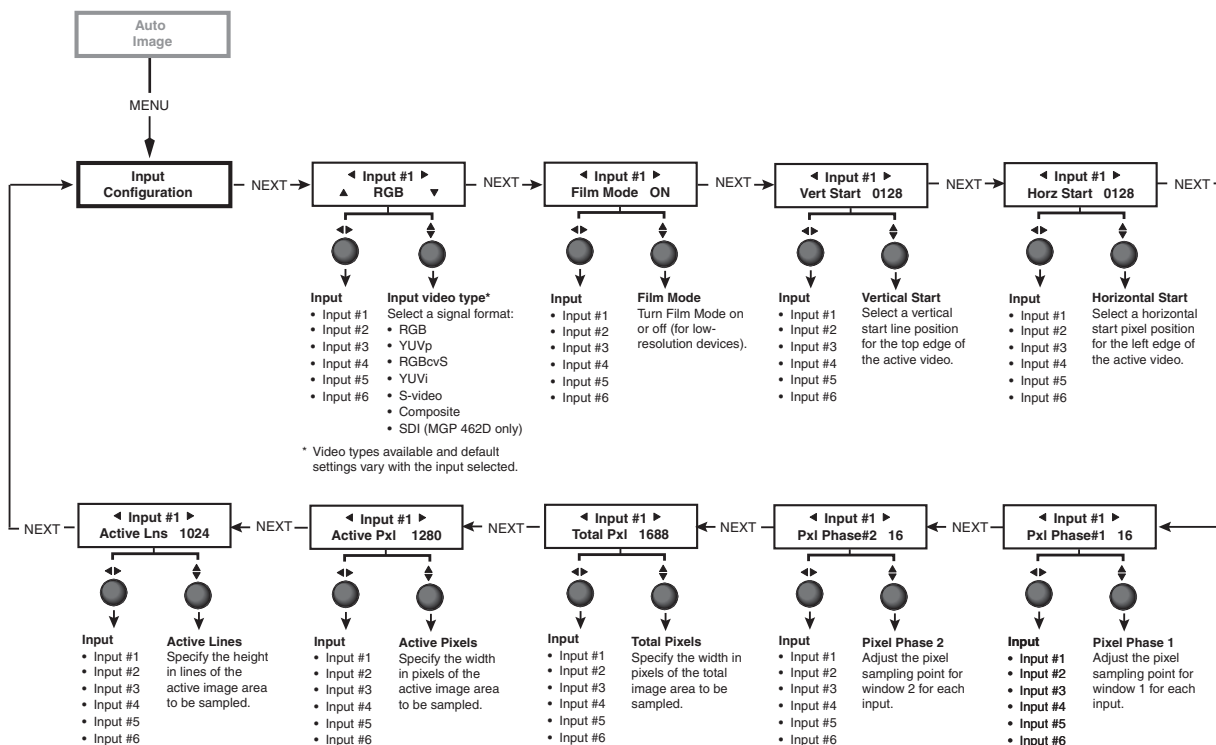

### Input Configuration menu flow

The following table lists the signal types available for each input.

Input video signal types						
Signal Type	Input 1	Input 2	Input 3	Input 4	Input 5	Input 6
RGB***	X*	X*	X*	X*		
YUVp	X	X	X	X		
RGBcvS	X	X	X	X		
YUVi	X	X	X	X	X	
S-video	X	X	X	X	X	X
Composite	X	X	X	X	X*	X*
SDI						X**

\* Default

\*\* MGP 462D only

\*\*\* RGBHV, RGBS, and RGsB are accepted with this input setting.

## Operation, cont'd

### Input configuration submenu adjustments

The table below shows which Adjust knob to use to make the selections and adjustments that are accessed through the Input Configuration submenus.

Input Configuration submenu	Horizontal knob adjustment	Vertical knob adjustment
<b>Video type</b> The following video signal types are accepted: RGB            S-video YUVp          Composite video YUVi          SDI (MGP 462D only) RGBcvS	Select input #1-6.	Select the desired video format for the displayed input. <b>Defaults:</b> Inputs 1-4 – <b>RGB</b> Inputs 5 and 6 – <b>Composite</b>
<b>Film mode</b> For low resolution inputs. The video signal type for the input you are configuring must be set to YUVi, composite video, or S-video in order to place the input in Film mode.	Select input #1-6. Shows current Film mode status for the displayed input: <b>ON, OFF, or na</b> (not applicable).	Select ON or OFF to turn 3:2 or 2:2 pulldown (Film mode) on and off for the selected input.
<b>Vertical start position</b> Distance in lines from the top edge of the input's total video display area to the top edge of its active area	Select input #1-6. Shows the current vertical start point for the displayed input.	Increase or decrease the value indicating the distance in lines from the top edge of the video display's total area to the top edge of its active area. The default is <b>128</b> .
<b>Horizontal start position</b> Distance in pixels from the left edge of the input's total video display area to the left edge of its active area	Select input #1-6. Shows the current horizontal start point for the displayed input.	Increase or decrease the value indicating the distance in pixels from the left edge of the video display's total area to the left edge of its active area. The default is <b>128</b> .
<b>Pixel phase 1</b> The point at which pixels are sampled for window 1. (The values cannot be changed when the input is YUVi, S-video, or composite video.)	Select input #1-6 for window 1.	Increase or decrease the displayed value to move the pixel sampling point for window 1 in to an optimal sampling point that ensures output clarity. The range of settings is <b>0-31</b> ; the default is <b>16</b> .
<b>Pixel phase 2</b> The point at which pixels are sampled for window 2. (The values cannot be changed when the input is YUVi, S-video, or composite video.)	Select input #1-6 for window 2.	Increase or decrease the displayed value to move the pixel sampling point for window 2 to an optimal sampling point that will ensure output clarity. The range of settings is <b>0-31</b> ; the default is <b>16</b> .
<b>Total pixels</b> Width in pixels of the total video display area. (The values cannot be changed when the input is YUVi, S-video, or composite video.)	Select input #1-64.	Increase or decrease the width in pixels of the total video display area of the selected input. The default is marked with an asterisk (*).
<b>Active pixels</b> Width in pixels of the active video area	Select input #1-6.	Increase or decrease the width in pixels of the active video area of the selected input. The default is marked with an asterisk (*).
<b>Active lines</b> Height in lines of the active video area	Select input #1-6.	Increase or decrease the height in lines of the active video area of the selected input. The default is marked with an asterisk (*).

## Output Configuration menu

The Output Configuration menu allows you to set the output resolution, refresh rate, output type, and sync polarity. The following flow diagram shows the submenus of the Output Configuration menu, and the adjustments that can be made from them.

**NOTE** *The menus time out and return to the default cycle after 20 seconds of inactivity. However, any selections you made with the Adjust knobs are saved and remain in effect.*

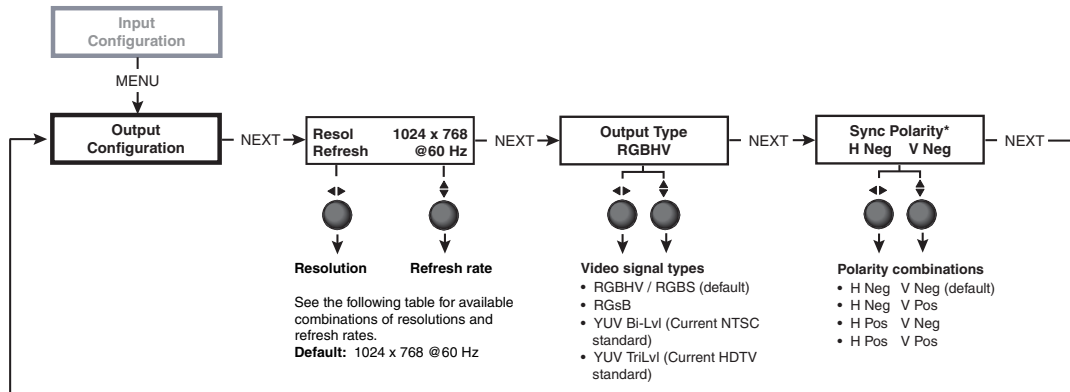

\*Appears only when sync polarity is applicable, based on other output settings.

### Output configuration menu flow

## Operation, cont'd

### Resolution and Refresh Rate submenu

Rotate the horizontal Adjust (◀▶) knob while in this submenu to select from one of the available resolutions. Rotate the vertical Adjust (⬆) knob while in this submenu to select one of the available refresh rates. The available resolution and refresh rates are listed in the following table.

Available Scaler Output Resolutions and Rates						
Resolution	Refresh rates					
	50 Hz	60 Hz	72 Hz	96 Hz	100 Hz	120 Hz
640 x 480	X	X	X	X	X	X
800 x 600	X	X	X	X	X	X
852 x 480	X	X	X	X	X	
1024 x 768	X	X	X	X		
1024 x 852	X	X	X	X		
1024 x 1024	X	X	X			
1280 x 768		X				
1280 x 1024	X	X				
1360 x 765		X				
1365 x 768		X				
1365 x 1024		X				
1366 x 768		X				
1400 x 1050	X	X				
1600 x 1200	X	X				
480p		X				
576p	X					
720p (HDTV)	X	X				
1080i (HDTV)	X	X				
1080p (HDTV)	X	X				



## Output Type submenu

Rotate either the horizontal Adjust (◀▶) or the vertical Adjust (⬆) knob to select the output signal type required by the display device. Available signal types are RGBHV, RGsB, YUV bi-level and YUV tri-level. The default is RGBHV.

**NOTE** Combined H and V Sync (S) is available on the "S" BNC connector when the unit is set to RGBHV.

## Sync Polarity submenu

The display device may require a particular combination of horizontal (H) and vertical (V) sync signal polarities. Rotate either the horizontal Adjust (◀▶) or the vertical Adjust (⬆) knob to select the sync polarity. The options are H-V-, H+V-, H-V+, H+V+, or na (appears when YUV Bi-lvl or YUV TriLvl is selected). The default is H-V-.

**NOTE** This submenu appears only when sync polarity is applicable based on the other selected output settings.

## Window Configuration menu

The Window Configuration menu allows you to set window front/back priority, add colored borders to the windows, select which window transition effect to use when muting (closing) a window, and specify the duration of the selected effect.

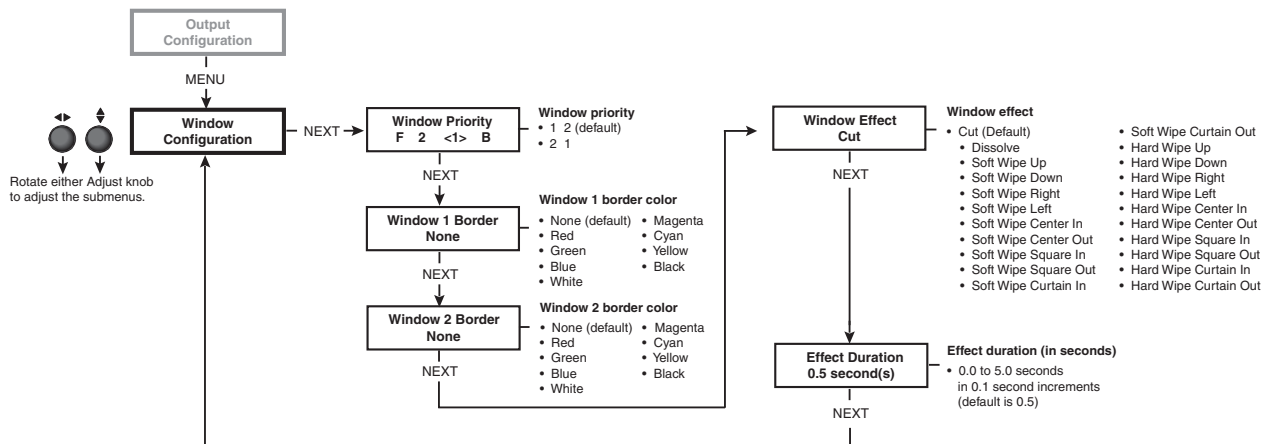

### Window Configuration menu flow

**NOTE** The menus time out and return to the default cycle after 20 seconds of inactivity. However, any selections you made with the Adjust knobs are saved and remain in effect.

## Window Priority submenu

The Window Priority submenu allows you to set how the windows will overlap one another. The submenu lists the two windows in order of their priority, from left to right. Rotate the vertical Adjust (⬆) knob to switch the priority between windows 1 and 2. (You do not use the horizontal Adjust knob with this submenu on the MGP 462.)

## Operation, cont'd

---

### Window 1 Border and Window 2 Border submenus

Use these submenus to select border colors for the two windows. Available options are *Red, Green, Blue, White, Magenta, Cyan, Yellow, and Black*. You can also select *None* (no border), which is the default setting.

### Window Effect submenu

Use this submenu to select a transition effect for the MGP 462 to use when muting and unmuting windows. To select a transition effect, follow these steps:

1. Press the Menu button repeatedly until Window Configuration is displayed on the LCD screen.
2. Press the Next button repeatedly until Window Effect is displayed.
3. Rotate either the horizontal Adjust (◀▶) or the vertical Adjust knob (⬆⬇) to select a transition effect.

### Available effects

**Cut** — A cut instantly mutes or unmutes the window. The effect duration does not apply.

**Dissolve** — A dissolve causes the window to fade out.



**Standard wipe** (soft wipe or hard wipe) — A standard wipe causes the new window to appear to unroll over the other one. The new window can roll from the top, bottom, left, or right side of the window. A soft wipe has a fuzzy leading edge; a hard wipe has a sharp edge.

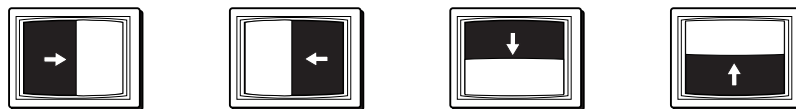

**Center wipe** — A center wipe causes the new window to appear to unroll over the other one in one of two ways:

- In from the top and bottom edges to the center of the window
- Out from the center to the top and bottom edges of the window

A center wipe can have a soft (fuzzy) leading edge or a hard (sharp) one.



---

**Square wipe** — A square wipe causes the new window to appear to unroll over the other one in one of two ways:

- In from the top, bottom, right, and left edges to the center of the window
- Out from the center to the four edges of the window

This effect creates a square shaped transition.

A square wipe can have a soft (fuzzy) leading edge or a hard (sharp) one.

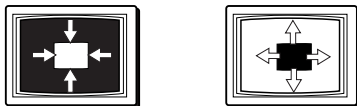

**Curtain wipe** — A curtain wipe causes the new window to appear to unroll over the other one in one of two ways:

- In from the left and right edges to the center of the window
- Out from the center to the right and left edges of the window

A curtain wipe can have a soft (fuzzy) leading edge or a hard (sharp) one.

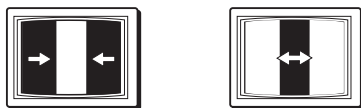

### Effect Duration submenu

Use this submenu to set the amount of time it takes the MGP 462 to complete a transition effect. Select from durations ranging from 0.0 to 5.0 seconds, in 0.1 second increments. (Duration is not available with the cut effect.)

To set an effect duration, follow these steps:

1. Press the Menu button until Window Configuration is displayed on the LCD screen.
2. Press the Next button until Effect Duration is displayed.
3. Rotate either the horizontal Adjust (◀▶) or the vertical Adjust (⬥) knob to select an effect duration.

# Operation, cont'd

## Window Text Configuration menu

This menu enables you to add a text box, containing up to 16 characters, to each window. The submenus allow you to enter the text for the label; select an on-screen position where the text will appear; and specify colors for the text, the text box background, and the border around the text.

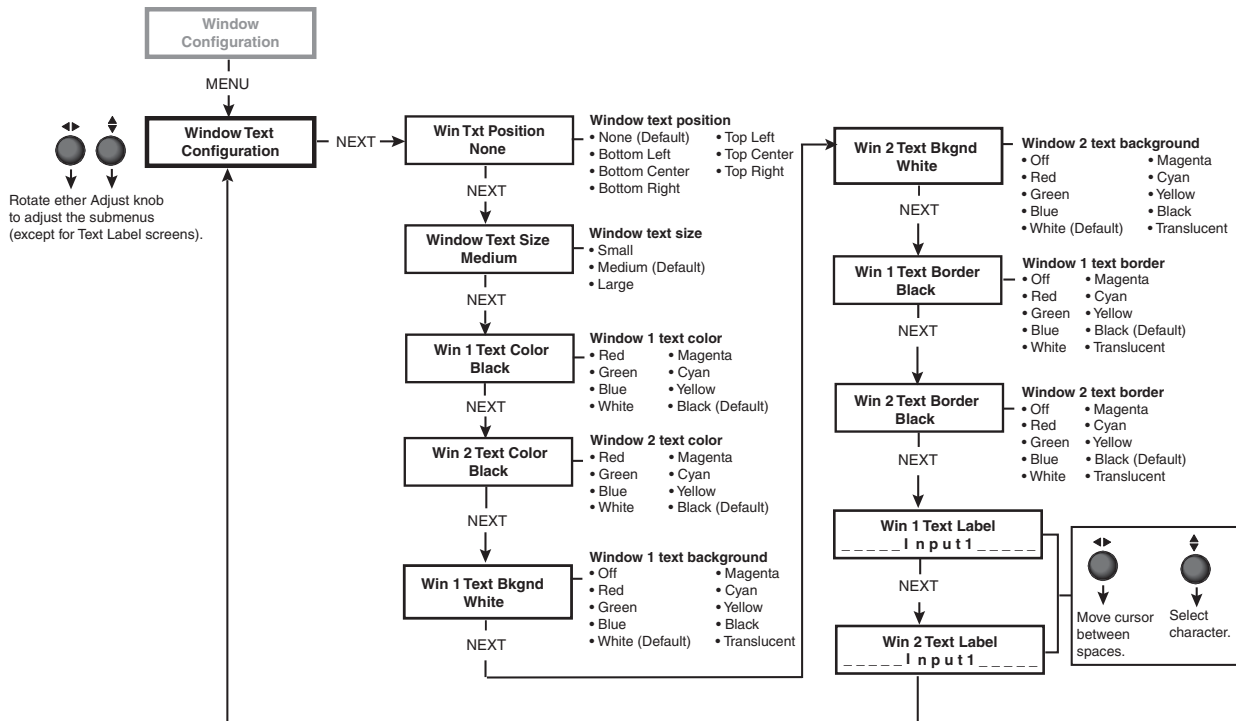

### Window Text Configuration menu flow

#### Window Text Position submenu

The Window Text Position submenu lets you place a text box at a specified location on a window.

Rotate either the horizontal Adjust (◀▶) or the vertical Adjust (⬆⬇⬅) knob to select one of the available text positions: *Bottom Left*, *Bottom Center*, *Bottom Right*, *Top Left*, *Top Center*, or *Top Right*.

To turn off window text, select *None* (the default).

#### Window Text Size submenu

The Window Text Size submenu allows you to select the size of the text in the window text box.

Rotate either the horizontal Adjust (◀▶) or the vertical Adjust (⬆⬇⬅) knob to select one of the available text sizes: *Small*, *Medium*, or *Large*. The default is *Medium*.

#### Windows 1 and 2 Text Color submenus

The Windows 1 and 2 Text Color submenus let you select the color of the text within the text box you place on window 1 or window 2.

Rotate either the horizontal Adjust (◀▶) or the vertical Adjust (⬆⬇⬅) knob to select one of the available window text colors. Options are *Red*, *Green*, *Blue*, *White*, *Magenta*, *Cyan*, *Yellow*, or *Black*. *Black* is the default.

---

### Windows 1 and 2 Text Background submenus

The Windows 1 and 2 Text Background submenus let you select a background color for the text box you place on window 1 or window 2.

Rotate either the horizontal Adjust (◀▶) or the vertical Adjust (⬆) knob to select one of the available background colors. Options are *Red, Green, Blue, White, Magenta, Cyan, Yellow, Black, or Translucent*. (*Translucent* provides a semitransparent background for the text, through which the video behind the text box is faintly visible.) The default is *White*.

### Windows 1 and 2 Text Border submenus

The Windows 1 and 2 Text Border submenus let you select a color for the border of the text box you place on window 1 or window 2.

Rotate either the horizontal Adjust (◀▶) or the vertical Adjust (⬆) knob to select one of the available border colors. Options are *Red, Green, Blue, White, Magenta, Cyan, Yellow, Black, or Translucent*. (*Translucent* provides a semiopaque border through which the window background can be seen.) The default is *Black*.

### Windows 1 and 2 Text Label screens

The Windows 1 and 2 Text Label screens enable you to create text in a text box to place on window 1 and/or window 2. The text is associated with the current input. The Text Label screens provide 16 spaces in which you can enter characters.

The default LCD display for Text Label shows the word *Input* and the number of the input that has been selected, preceded and followed by five dashes. (See the example below.)



You can replace these characters with other characters by turning the Adjust knobs as follows:

- Rotate the horizontal Adjust (◀▶) knob to move the cursor (which appears as an underscore) to the space you want to change.
- Rotate the vertical Adjust (⬆) knob to change the character displayed in the selected space.

The following characters are available:

**Symbols:** : / - + " \_ □ (blank character).

**Numerals:** 0 through 9

**Letters:** Lowercase a through z, uppercase A through Z

**Spaces**

To remove a character space from the text box, select □, then reposition the characters so that the blank character is at the **end** of the line.

# Operation, cont'd

## Background Capture menu

The Background Capture menu allows you to capture the image that is currently displayed on the output screen and save it as a bitmap (.bmp) file with one of 16 designated image names. You can then recall the image and use it as a background.

Background Capture also can be done via Ethernet, using the MGP 462 Web pages. See chapter 5, *Ethernet Control*, for further information.

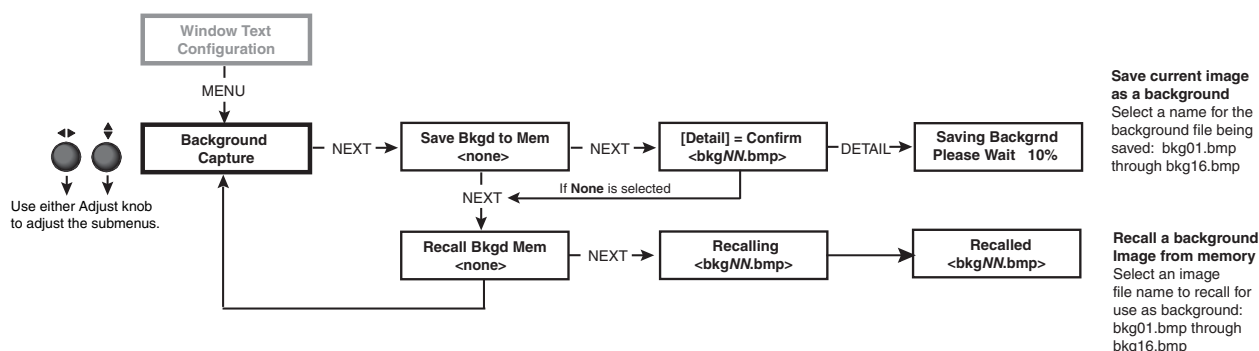

### Background Capture menu flow

### Memory space for background files

The MGP 462 has 16 MB of user storage space that can be used for saved backgrounds and uploaded user Web pages. The number of images that you can save depends on the size (in kB) of the image bitmap file and the resolution. The following table shows the number of images you can store based on different resolutions.

Resolution	640 x 480	800 x 600	1024 x 768	1280 x 1024	1400 x 1050	1600 x 1200
Image size (KB)	900.00	1406.25	2304.00	3804.00	4306.64	5625.00
Total images	16*	11	6	4	3	2

\*16 is the maximum number of images that can be saved as backgrounds.

To calculate the size of a bitmap file for any image of any specified size, use this formula:

$$\text{file size (in kilobytes)} = (\text{horizontal} \times \text{vertical} \times 3) + 54(\text{file header ID})$$

### Saving a background to memory

To save the current image to memory for use as a background, follow these steps:

1. Press Menu repeatedly until the Background Capture screen is displayed. Press Next once to display the Save Background to Memory submenu screen.
2. Rotate either Adjust knob to select a background file name (bkg01.bmp through bkg16.bmp) with which to save the image.

**NOTE** You can save the background image only under one of the file names on this menu; you cannot make up a different name for it.

If you do not want to save the image, select None, then press Next. The Recall Background submenu screen is displayed.

3. Press the Next button to save the image as a bitmap (.bmp) file. The LCD screen displays the message "[Detail] = Confirm filename.bmp."

**NOTE** The unit supports 24-bit bitmap files only. Their file names must have the format Bkgnn.bmp.

**CAUTION** The image that you save overwrites any existing image file with the same file name.

- Press the Detail button (the top button located at the immediate left of the LCD screen).

The LCD screen displays the message “Saving Background Please Wait,” along with an incrementing number showing the percent of the file that has been captured. The time the MGP takes to save an image varies depending on the image file size. For example, a 102 by 768 pixel image takes about 90 seconds to save.

**NOTE** The unit does not respond to any commands while it is saving an image.

- If you want to recall a background file for the output display, press Next within 20 seconds. (After 20 seconds, the MGP 462 returns to the default cycle.)

### Recalling a background from memory

To recall an image from memory for use as a background:

- Access the Recall Background from Memory submenu.
- Rotate either Adjust knob to select one of background image files (bkg01.bmp through bkg16.bmp) to use as the output background.

To perform no action, press the Menu button.

- Press the Next button to recall the image. The LCD screen displays the message “Recalling filename.bmp” while the image is being recalled, then “Recalled filename.bmp” after the recall is complete.

### Advanced Configuration menu

Use the Advanced Configuration menu to set the background color, turn Blue Mode on and off, select test patterns, and select the serial communication mode. You can also view the MGP’s internal temperature and reset the unit to its factory defaults.

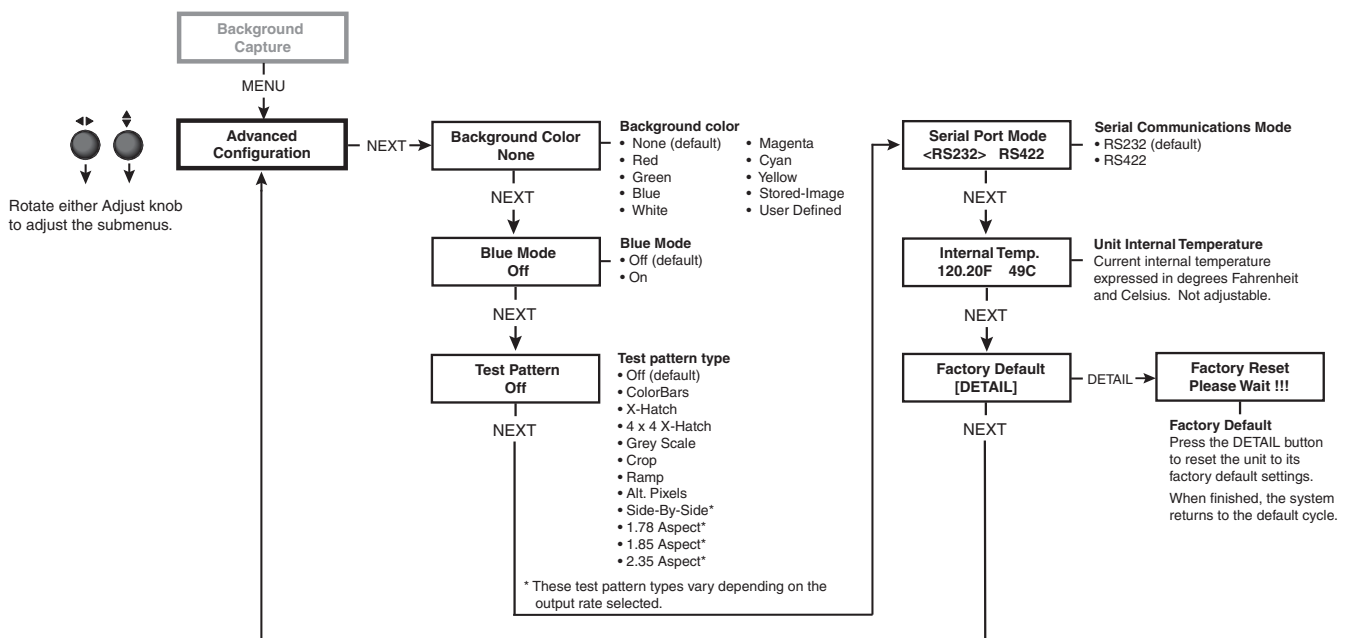

**Advanced Configuration menu flow**

## Operation, cont'd

---

### Background Color submenu

Rotate either Adjust knob to select a background color for the output screen. Options are *None, Red, Green, Blue, White, Magenta, Cyan, Yellow, Stored-Image, and User Defined*.

- *None*, the default setting, produces a black background.
- *Stored-Image* is the saved background that was most recently recalled. When a captured background is recalled, the *Stored-Image* option is automatically selected. Select this option if you want to return to the recalled background after having changed to a different background color.
- *User Defined* is the background color that you can set by using an SIS command. See chapter 4, *Software Configuration and Control*, for the command syntax.

### Blue Mode submenu

Blue Mode causes only sync and blue video signals to be passed to the display. This can aid in the setup of the MGP 462's color and tint. While in the Blue Mode submenu, rotate either Adjust knob to turn Blue Mode on and off.

### Test Pattern submenu

Several test patterns are available via this submenu to adjust the display device for color, convergence, focus, resolution, contrast, grayscale and aspect ratio. Use either Adjust knob to select a test pattern. The available patterns are:

- Color Bars
- X-Hatch (16 by 12 crosshatch)
- 4 x 4 X-Hatch (4 by 4 crosshatch)
- Grayscale (Grey Scale)
- Crop
- Ramp
- Alt. Pixels (alternating pixels)
- Side-By-Side (4 by 3 or 16 by 9 side by side crop)
- 1.78 Aspect (film aspect ratio 1.78)
- 1.85 Aspect (film aspect ratio 1.85)
- 2.35 Aspect (film aspect ratio 2.35)

The default setting is "Off." The side-by-side crop and aspect ratio patterns available from the submenu vary depending on the aspect ratio of the output rate.





Color Bars (8)

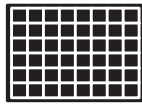

Crosshatch 16x12

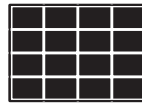

Crosshatch 4x4



Grayscale



Ramp

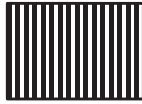

Alt Pixels



Crop



4x3 Side-by-side Crop



1.78 Aspect Ratio



1.85 Aspect Ratio



2.35 Aspect Ratio



16x9 Side-by-side Crop

### Test patterns available for the MGP 462

#### Serial Port Mode submenu

Use the Serial Port Mode submenu to select either RS-232 or RS-422 for the MGP's serial communication standard. Turn either Adjust knob to move the brackets on the LCD screen to RS232 or RS422.

#### Internal Temperature screen

The Internal Temp submenu displays the unit's current internal temperature. The MGP 462 displays the temperature in degrees Fahrenheit and Celsius. This is an information-only screen; no adjustments can be made on it.

#### Factory Default submenu

This submenu lets you reset the MGP 462 to the default settings with which it was delivered from the factory. Press the Detail button (the top button immediately to the left of the LCD screen) to initiate the reset.

## Picture Controls

The MGP 462 has six picture control buttons located on the front panel to the left of the LCD screen. You can use these buttons to adjust size, position, brightness and contrast, color and tint, detail, and magnification (zoom).

**NOTE** *Picture controls are window-dependent. You set the values separately for each window.*

**NOTE** *For Window/Image Size, Window/Image Position, and Window Image Zoom, pressing the button repeatedly switches back and forth between window settings and image settings.*

The table on the next page shows the buttons, their functions, and how to make adjustments. (In the Display column, *n* stands for a single digit, 0 through 9.)

## Operation, cont'd

### Adjusting the picture controls

Make image adjustments to an input using the picture control buttons on the front panel. When you select a picture control button, it lights with the same color (green or red) as the selected buttons for the window and input that it will adjust. When you select a control button, the window button for the most recently adjusted window lights, indicating that it is being adjusted. The table on the next page shows the picture control adjustments that can be made from the front panel.

Button	Display	Function	Range	Adjust Knob
Window/ Image Size	WINDOW <i>n</i> SIZE: H= <i>nnnn</i> V= <i>nnnn</i>	Enlarge or shrink window 1 or 2.	<b>Min:</b> 1/16 of the output rate <b>Max:</b> Output rate	<b>For H (width):</b> horizontal ◀▶ Adjust knob
	(Press button twice.) IMAGE # <i>n</i> SIZE: H= <i>n</i> V= <i>n</i>	Enlarge or shrink the image within the window.	<b>Min:</b> 1/16 of the output rate <b>Max:</b> 2 times the output rate	<b>For V (height):</b> ▲ vertical ▼ Adjust knob
Bright/ Cont	BRIT      CONT <i>nnnn</i> <i>nnnn</i>	<b>Brightness:</b> Increase or decrease intensity of video light on screen.  <b>Contrast:</b> Increase or decrease range of image light and dark values.	<b>Brightness:</b> 000-127 <b>Default:</b> 064  <b>Contrast:</b> 000-127 <b>Default:</b> 064	<b>Bright:</b> horizontal ◀▶ Adjust knob  <b>Contrast:</b> ▲ vertical ▼ Adjust knob
Detail	DETAIL <i>nnnn</i>	Adjust image sharpness.	000 - 127 <b>Default:</b> 064	Either
Window/ Image Position	WINDOW <i>n</i> START: H=± <i>nnnn</i> V=± <i>nnnn</i>	Position window 1 or 2 on the screen in relation to the screen's center.	<b>Default:</b> 0000 ± the output rate	<b>For H:</b> horizontal ◀▶ Adjust knob
	(Press button twice.) IMAGE # <i>n</i> START: H=± <i>nnnn</i> V=± <i>nnnn</i>	Position image within the window in relation to the window center.	<b>Default:</b> 0000 ± the output rate	<b>For V:</b> ▲ vertical ▼ Adjust knob
Color/ Tint	COLOR      TINT <i>nnnn</i> <i>nnnn</i>	<b>Color:</b> Adjust color intensity. (At lowest adjustment, all colors are shades of gray.)  <b>Tint:</b> Change the appearance of colors.	<b>Color:</b> 000 - 127 <b>Default:</b> 064  <b>Tint:</b> 000 - 127 <b>Default:</b> 064	<b>Color:</b> horizontal ◀▶ Adjust knob  <b>Tint:</b> ▲ vertical ▼ Adjust knob
Window/ Image Zoom	WINDOW <i>n</i> ZOOM: H= <i>nnnn</i> V= <i>nnnn</i>	Increase/decrease the size of the image in the selected window while keeping the aspect ratio constant.	<b>Min:</b> 1/16 of the output rate <b>Max:</b> Output rate	<b>For H:</b> horizontal ◀▶ Adjust knob
	(Press button twice.) IMAGE # <i>n</i> ZOOM: H= <i>nnnn</i> V= <i>nnnn</i>	Increase/decrease the size of the image in the selected window while keeping the aspect ratio constant.	<b>Min:</b> 1/16 of the output rate <b>Max:</b> 2 times the output rate	<b>For V:</b> ▲ vertical ▼ Adjust knob

---

To adjust the picture controls, follow these steps:

1. Press the Input button for the input that you want to adjust, if it is not currently selected.
2. Press the Window 1 or 2 button to select the window you want to adjust.
3. Press the button for the desired picture control: **Window/Image Size** (sizing), **Bright/Cont** (brightness and contrast), **Detail** (sharpness), **Window/Image Position** (centering), **Color/Tint** (color and tint), or **Window/Image Zoom** (magnification).
4. Rotate the horizontal Adjust (◀▶) and/or vertical Adjust (⬥) knobs to select a level from the available range.
5. Repeat steps 1 through 4 for each image adjustment to be made for the selected input/window.

**NOTE** *The LCD screen may display “na,” indicating that an adjustment is not available, in place of a number if that adjustment does not apply to the input’s video format.*

## Memory Presets

### Window presets

The MGP 462 allows up to 25 window presets that save information for both windows. Use the Preset Save/Recall and Enter buttons on the front panel to save and recall presets to and from their specified memory locations. Window presets can also be saved, recalled, and named using SIS commands via an RS-232/422 interface or the product Web pages using an Ethernet connection (see chapter 4, *Software Configuration and Control*, and chapter 5, *Ethernet Configuration and Control*, for more information).

The following settings can be saved in a window preset:

Window border color	Label text color
Window priority	Label border color
Window transition effect	Label background color
Transition effect duration	Window background setting
Label text size	Window size/position
Label location	Window mute status

### Saving a window preset

To save a window preset using the front panel buttons, follow these steps:

1. Set the parameters listed above as desired for windows 1 and 2.
2. Press and **hold** the Preset Recall/Save button for at least 2 seconds. The LCD screen displays the following:

WINDOW PRESET  
Save to #01

3. Rotate either Adjust knob to select one of the 25 available window preset locations in which to save the settings. (These location numbers are also the preset numbers.)

## Operation, cont'd

---

4. Press the Enter button to save the current window setting in the preset location number you selected. The LCD screen shows a message indicating that the preset is being saved to the selected memory location, followed by a message that the preset has been saved.

The following examples show a preset saved to location 1.

```
WINDOW PRESET
Saving to #01
```

```
WINDOW PRESET
#01 SAVED
```

If you want to exit this menu without saving any changes, repeatedly press the Preset Recall/Save button until the following message appears on the LCD screen, then press the Enter button to exit the Window Presets dialog.

```
WINDOW PRESET
[ENTER] TO EXIT
```

### Recalling a window preset

To recall a window preset using the front panel buttons:

1. Press and release the Preset Recall/Save button. The following message appears on the LCD screen:

```
WINDOW PRESET
Recall #01 woINP
```

2. If you do not want to recall the input whose number was displayed when the preset was saved, proceed to step 3.

If you want to recall the input with the preset, press the Preset Recall/Save button again. The following message appears:

```
WINDOW PRESET
Recall #01 wINP
```

If you select this option, the inputs change to display the sources that were displayed at the time the preset was saved, along with all input settings specified by input presets. (See *Input presets*, on the next page.)

3. Use either Adjust knob to select a window preset number to recall.

- Press the Enter button to recall the preset you selected. The LCD screen shows a message indicating that the preset was recalled. The following example shows a message indicating that preset 1 was recalled.



If you want to exit this menu without recalling a preset, repeatedly press the Preset Recall/Save button until you see the message Window Preset [Enter] to Exit. Press the Enter button to exit the Window Presets dialog.

### Default presets

The following figure shows the factory default preset window configurations. These presets can be used for any output rate. If you overwrite them, you can recover them by selecting Factory Defaults from the Advanced Configuration menu. (See *Advanced Configuration menu*, earlier in this chapter.)

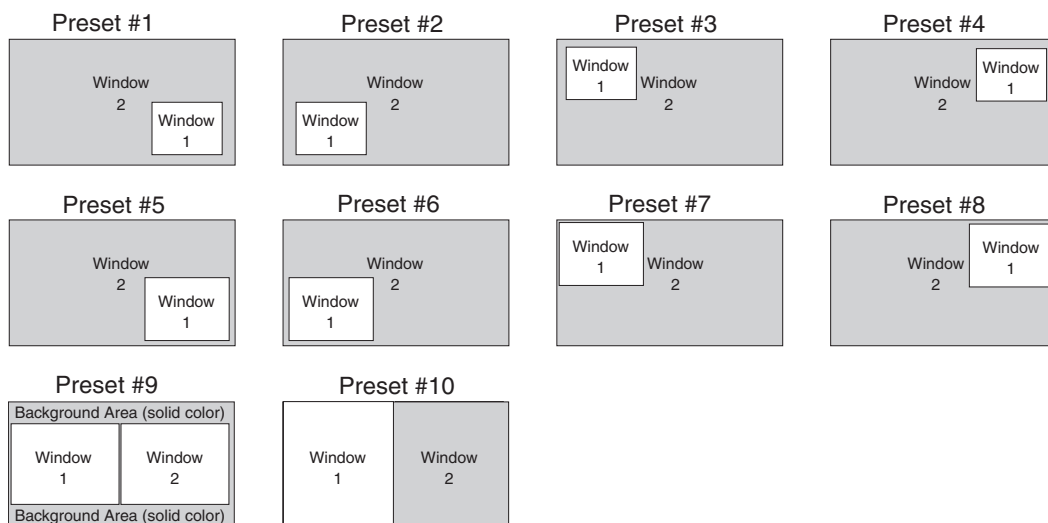

### Factory default preset configurations

### Input presets

The MGP 462 has 128 input preset locations, to which you can save signal type, input configuration settings, picture control settings, and window text for any of the inputs. These presets can be saved and recalled using the SIS commands via the RS-232/422 connection or via Ethernet using the MGP 462 Web pages (see chapters 4 and 5 for further information).

The following settings are contained in the input presets:

Input Type	Horizontal Start	Total Pixels
Input Name	Vertical Start	Active Pixels
Film Mode On/Off	Pixel Phase	Active Lines
Brightness	Contrast	Color
Tint	Detail (sharpness)	Image Size/Position*

\*Image size and position are saved as percent of the window, so that the input preset can be used for any size window.

### Additional Functions

#### Freeze mode

The front panel Freeze buttons are the first buttons on the left. Press these buttons to freeze the current image from the currently selected input in window 1 (top button) and/or window 2 (bottom button). When the Freeze button for a window is selected, it lights orange. You can also freeze the windows using the Windows-based configuration software or SIS commands via the RS-232/422 connection.

If you switch inputs while a window is frozen, the freeze mode is cancelled and the new input's image appears in the window.

#### Front panel security lockout (executive mode)

To prevent access by unauthorized users or accidental changes to the MGP 462's settings, some of the front panel controls can be locked using executive mode. When you place the MGP in executive mode via the front panel, the picture control buttons and the menu selection buttons are locked. All other functions (input and window selection, freezing, and preset saving and recalling remain accessible. The RS-232/422 and Ethernet ports also remain unlocked.

You can enable or disable executive mode when the system is in the default cycle. To turn executive mode on and off, press the Window/Image Size and the Window/Image Position buttons simultaneously, and hold them for at least 2 seconds. The default is Disabled.

You can also enable and disable executive mode by using the SIS commands or the Windows-based control software via the RS-232/422 interface (see chapter 4, *Software Configuration and Control*, for more information).

**NOTE** *If you place the MGP in executive mode by using SIS commands or the Windows-based control software, you have an additional type of executive mode available. In executive 2 mode, all the front panel controls are locked. This mode is available only through SIS commands. See chapter 4, Software Configuration and Control, for information on SIS commands, or the control software's Help program.*

#### Resetting the unit

There are four reset modes (numbered 1, 3, 4, and 5 for the sake of comparison with Extron IPL products) that you can access by pressing the Reset button on the rear panel. The Reset button is recessed, so use a pointed stylus, ballpoint pen, or Extron Tweaker to press it. See the table on the next page for a summary of the reset modes.

**CAUTION** *Review the reset modes carefully. Using the wrong reset mode may result in unintended loss of flash memory programming, port reassignment, or processor reboot.*

**NOTE** *The reset modes listed in the table close all open IP and Telnet connections and close all sockets. Also, each mode is a separate function, not a continuation from mode 1 to mode 5.*

Reset Mode Comparison/Summary			
Mode	Activation	Result	Purpose/Notes
1	Hold down the recessed Reset button while applying power to the unit.	<b>Mode 1 causes the MGP 462 to revert to the factory default firmware.</b> Event scripting does not start if the unit is powered on in this mode. All user files and settings (drivers, audio adjustments, IP settings, etc.) are maintained.	Use mode 1 to remove a version of firmware if incompatibility issues arise.
3	Hold down the Reset button for about 3 seconds, until the Reset LED blinks once. Then, within 1 second, press Reset again briefly (for less than 1 second).	<b>Mode 3 turns events on or off.</b> During resetting, the Reset LED flashes 2 times if events are starting; 3 times if events are stopping.	Events must be turned on if you want to change IP settings or scheduling.
4	Hold down the Reset button for about 6 seconds, until the Reset LED has blinked twice (once at 3 seconds, once at 6 seconds). Then, within 1 second, press Reset briefly (for less than 1 second).	<p><b>Mode 4 does the following:</b></p> <ul style="list-style-type: none"> <li>• Enables ARP capability.</li> <li>• Sets the IP address back to factory default.</li> <li>• Sets the subnet back to factory default.</li> <li>• Sets the default gateway address back to the factory default.</li> <li>• Sets port mapping back to factory default.</li> <li>• Turns DHCP off.</li> <li>• Turns all events off.</li> </ul> <p>The Reset LED flashes 4 times in quick succession during reset.</p>	Mode 4 enables you to set IP address information using ARP and the MAC address.
5	Hold down the Reset button for about 9 seconds, until the Reset LED has blinked three times (once at 3 seconds, once at 6 sec., once at 9 seconds). Then, within 1 second, press Reset briefly (for less than 1 second).	<p><b>Mode 5 performs a complete reset to factory defaults (except the firmware).</b></p> <ul style="list-style-type: none"> <li>• Does everything mode 4 does.</li> <li>• Resets everything that was set via the Real Time Adjustments part of the control program: all video settings and miscellaneous options.</li> <li>• Resets all IP options.</li> <li>• Removes/clears all files from the processor.</li> </ul> <p>The Reset LED flashes 4 times in quick succession during the reset.</p>	Mode 5 is useful if you want to start over with control software configuration and uploading, and to replace events.

**Operation, cont'd**

---





# 4 Chapter Four

## **Software Configuration and Control**

Setting Up RS-232/RS-422 Communication

Using Simple Instruction Set (SIS™) Commands

Using the Windows®-based Control Software

Using the Button Label Generator

# Software Configuration and Control

## Setting up RS-232/RS-422 Communication

The MGP 462's RS-232/422 port is used to connect the MGP to a host or external controlling device, such as a computer or control system, which can generate the proper command codes and recognize the processor's responses.

**NOTE** *The cable used to connect the RS-232/422 port to a computer or control system may need to be modified by removing pins or cutting wires. If unneeded pins are connected, the processor may cease to function. See chapter 2, Installation, for more information on wiring the connectors.*

The RS-232/422 connector on the rear panel is a 9-pin D female connector (see the illustration at right) with the following pin assignments.

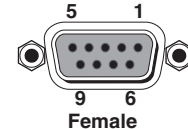

Pin	RS-232 function	Description
1	–	No connection
2	Tx	Transmit data
3	Rx	Receive data
4	–	No connection
5	Gnd	Signal ground
6	–	No connection
7	–	No connection
8	–	No connection
9	–	No connection

Pin	RS-422 function	Description
1	–	No connection
2	Tx-	Transmit ground
3	Rx-	Receive ground
4	–	No connection
5	Gnd	Signal ground
6	–	No connection
7	Rx+	Receive data
8	Tx+	Transmit data
9	–	No connection

### Connector pin assignments

There are several programs that enable you to connect the MGP 462 to a computer or control device via the RS-232/422 interface, and to enter commands. HyperTerminal for Windows is one such program that is commonly used on PCs. For any program that you use, set up communication using the following protocol:

Baud rate: 9600  
Data bits: 8  
Parity: None  
Stop Bits: 1  
Flow Control: None

## Using Simple Instruction Set (SIS™) commands

### Host-to-MGP communications

The MGP 462 accepts SIS (Simple Instruction Set) commands through the RS-232/422 port. SIS commands consist of one or more characters per command field. They do not require any special characters to begin or end the command character sequence. Each response to an SIS command ends with a carriage return and a line feed (CR/LF = ↵), which signals the end of the response character string. A string is one or more characters.

### MGP-initiated messages

When a local event such as a front panel selection or an adjustment takes place, the MGP 462 responds by sending a message to the host. No response is required from the host. Examples of MGP-initiated messages are listed below (underlined).

(C) Copyright 2006, Extron Electronics, MGP462, Vx.xx↵

The MGP 462 sends the copyright message when it is first powered on. Vx.xx is the firmware version number.

---

Out *nn* In *nn* ↵ (where Out *nn* is the window number, and In *nn* is the input number).

The MGP 462 sends this response when an input is switched.

### **Error responses**

When the MGP 462 receives a valid SIS command, it executes the command and sends a response to the host device. If the MGP is unable to execute the command because the command is invalid or contains invalid parameters, it returns an error response to the host. The error response codes are:

- E01 — Invalid input channel number (too large)
- E09 — Invalid function number (too large)
- E10 — Invalid command
- E11 — Invalid preset number
- E12 — Invalid output number (applies for addressing windows)
- E13 — Invalid value (out of range)
- E14 — Invalid command for this configuration
- E17 — Invalid command for signal type
- E24 — Privilege violation
- E26 — Maximum number of users connected has been exceeded
- E27 — Invalid event number
- E28 — Bad filename/File not found

### **Error response references**

The following superscripted numbers are used within the command descriptions on the following pages to identify commands that may respond as shown:

- <sup>14</sup> = Commands that give an E14 (not valid for this configuration) response if the unit's current configuration doesn't support that command
- <sup>24</sup> = Commands that give an E24 (privilege violation) response if you are not logged in at the administrator level.
- <sup>27</sup> = Commands that may yield an E27 (invalid event number) response.
- <sup>28</sup> = Commands that may give an E28 (file not found) response.

### **Telnet and Web communications**

The MGP 462 can also be controlled via an IP connection using either Telnet (port 23) or a Web browser (port 80). The ASCII and URL commands listed in the tables later in this chapter perform the same functions, but they are encoded differently to accommodate the requirements of each port (Telnet or browser).

The ASCII to hexadecimal (hex) conversion table on the next page is for use with the command/response tables for the IP control port commands, which begin on page 4-18.

# Software Configuration and Control, cont'd

ASCII to HEX Conversion Table										Esc	1B	CR	0D	LF	0A
20	!	21	"	22	#	23	\$	24	%	25	&	26	'	27	
(	28	)	29	*	2A	+	2B	,	2C	-	2D	.	2E	/	2F
0	30	1	31	2	32	3	33	4	34	5	35	6	36	7	37
8	38	9	39	:	3A	;	3B	<	3C	=	3D	>	3E	?	3F
@	40	A	41	B	42	C	43	D	44	E	45	F	46	G	47
H	48	I	49	J	4A	K	4B	L	4C	M	4D	N	4E	O	4F
P	50	Q	51	R	52	S	53	T	54	U	55	V	56	W	57
X	58	Y	59	Z	5A	[	5B	\	5C	]	5D	^	5E	_	5F
`	60	a	61	b	62	c	63	d	64	e	65	f	66	g	67
h	68	i	69	j	6A	k	6B	l	6C	m	6D	n	6E	o	6F
p	70	q	71	r	72	s	73	t	74	u	75	v	76	w	77
x	78	y	79	z	7A	{	7B		7C	}	7D	~	7E	DEL	7F

**ASCII to hexadecimal character conversion table**

The command/response tables list valid ASCII (for Telnet) command codes, the corresponding URL encoded (for Web browsers) command codes, the MGP's responses to the host, and a description of the command's function or results from executing the command.

- Upper- and lowercase characters may be used interchangeably in the command field unless otherwise specified.
- Commands may be sent back-to-back without spaces; for example, **2\*2!2\*0B**.
- Numbers can be entered as 1, 2, or 3 digits; for example, **8V = 08V = 008V**.
- There are a few differences in how to enter the commands depending on whether you are using Telnet or a Web browser.
- For control via a Web browser, all **nonalphanumeric characters** must be represented as the hexadecimal equivalent, %xx, where xx represents the two-character hex byte. For example, a comma (,) would be represented as %2C.
- When using these commands through a Web browser, the URL reference is used to shorten the examples. "URL" refers to the full URL of the control interface and Web page reference, including all path information; for example, **http://192.168.100.10/myform.htm**.
- Some characters differ depending on the method you use to send the commands:
 

<u>Telnet</u>	<u>Web browser</u>
Escape (hex 1B)	W [must <b>not</b> be encoded]
Carriage return (hex 0D)	Pipe character ( ) [must <b>not</b> be encoded]

**NOTE** *With Telnet you can use either the "Escape" commands or the "W" commands, and either the carriage return or the pipe character. With the Web browser, you are required to use the "W" commands and the pipe character.*

In either method, the data string (shown in braces as {data} in the Command/response table) is directed to the specified port, and must be encoded if it is nonalphanumeric.

## Symbol definitions

• = Space

↵ = Carriage return with line feed

← = Carriage return with no line feed

**Esc** = Escape

<sup>24, 27, 28</sup> = Superscripts indicate the error message displayed if the command is entered incorrectly or with invalid parameters. See *Error responses*, earlier in this chapter.

| = Pipe (vertical bar) character

**X1** = Specific port number (01-99)

**X2** = Command data section

**NOTE** *For Web encoding only:*

*Data is directed to the specified port and must be encoded if it is nonalphanumeric. Because data can include either command terminator, it must be encoded as follows when used within the data section:*

*Space (Hex 20) must be encoded as %20 (Hex:25 32 30)*

*Plus sign (Hex 2B) must be encoded as %2B (hex 25 32 42).*

**X3** = Greenwich Mean Time (GMT) offset value (-12:00 to 14:00) in hours and minutes (hh:mm)

**X5** = On/Off  
0 = off/disable  
1 = on/enable

**X11** = Version number (listed to two decimal places)

**X12** = Name that you give the unit. This name is a text string of up to 24 characters drawn from the alphabet (A-Z), digits (0-9), and the minus sign/hyphen (-). The first character must be an alpha character. The last character must **not** be a minus. No blank or space characters are permitted, and no distinction is made between upper- and lowercase.

**X13** = Local date and time format

**Set** format (MM/DD/YY-HH:MM:SS);  
e.g., 06/21/02-10:54:00

**Read** format (day of week, date month year (HH:MM:SS), e.g., Thu, 20 Feb 2003 18:19:33

**X14** = IP address (xxx.xxx.xxx.xxx); leading zeros in each of 4 fields are optional in setting values, and are suppressed in returned values.

**X15** = Mail domain name (e.g., Extron.com)

**X17** = Time in tens of milliseconds to wait for characters coming into a serial port before terminating the connection (min = 0, max = 32767, and default = 10 = 100 ms). The response is returned with leading zeros. In RS-232 commands, **X17** and **X20** are optional. Commands using both **X17** and **X20** must have either both values equaling zero or both values set to nonzero.

**X18** = Hardware (MAC) address (xx-xx-xx-xx-xx-xx)

**X19** = Subnet mask (xxx.xxx.xxx.xxx). Leading zeros are optional in setting values in each of four fields, and are suppressed in returned values.

**X20** = Time in tens of milliseconds to wait **between** characters coming into a serial port before terminating the connection (min = 0, max = 32767, and default = 2 = 20 ms). The response is returned with leading zeros. In RS-232/422 commands, **X17** and **X20** are optional. Commands using both **X17** and **X20** must have both values either equal zero or both set to nonzero.

**X21** = Parameter to set either the Length of the message to receive or a Delimiter value.  
L = byte count (min = 0, max = 32767, and default = 0L [0 byte count]).  
D = decimal value for the ASCII character (min = 0, max = 00255, and default = 00000L).

Value is placed prior to parameter; for example, 3 byte length = 3L, and the ASCII 0A delimiter is 10D. This parameter is case sensitive; you must use uppercase D and L. The response is returned with leading zeros. (**X21** is an optional parameter.)

**X22** = Verbose response mode  
0 = clear/none  
1 = verbose mode  
2 = tagged responses for queries  
3 = verbose mode and tagged responses for queries  
Default = 0 for Telnet connections; 1 for RS-232/422 control

**X23** = Priority status for receiving timeouts.  
0 = use Send data string command parameters.  
1 = use Configure receive timeout command parameters.  
Default = 0.

**X25** = Baud rate: 300, 600, 1200, 1800, 2400, 3600, 4800, 7200, 9600, 14400, 19200, 28800, 38400, 57600, or 115200

**X26** = Parity (only the first letter is needed):  
Odd  
Even  
None  
Mark  
Space

**X27** = Data bits: 7, 8

**X28** = Stop bits: 1, 2

**X29** = Port type  
0 = RS-232  
1 = RS-422

**X30** = Flow control (only the first letter is needed):  
Hardware  
Software  
None (the default)

**X31** = Data pacing (specified in milliseconds between bytes): 0000 - 1000.

**X33** = Password (12 characters = maximum length; no special characters are allowed.)

**NOTE** *A user password cannot be assigned if no administrator password exists; the E14 error code is returned. If the administrator password is cleared, the user password is also removed.*

## Software Configuration and Control, cont'd

- X34** = Daylight savings time (used in the northern hemisphere [USA] and parts of Europe and Brazil)  
0 = off/ignore  
1 = on
- X35** = Event number, range = 0 - 99
- X36** = Event buffer  
0 = receive  
1 = user  
2 = NVRAM
- X37** = Event buffer offset (range = 0 to MaxBufferSize)
- X38** = Event data size  
b = bit  
B = byte (8 bits)  
S = short (16 bits)  
L = long (32 bits)
- NOTE** *This parameter is case sensitive.*
- X39** = Event data to write
- X44** = Number of bytes to read
- X45** = E-mail event number (1 - 64)
- X46** = E-mail recipient's address
- X47** = Name of e-mail file to be sent  
First line of the file is the subject.  
The rest is the body of the e-mail.
- X49** = Default name: a combination of the model-name and the last 3 character pairs of the unit's MAC address (e.g., MGP-462-00-02-3D)
- X51** = (Ethernet only) Number of seconds before timeout on IP connections (min = 1, max = 6500, and default = 30 = 300 seconds).  
If no data is received during the timeout period, the Ethernet connection is closed. Each step is 10 seconds. When the unit is connected via RS-232/422, only the global timeout commands apply; anything else returns an E13 error code. The response is returned with leading zeros.
- X52** = Connection's security level  
0 = not logged in  
1 = user  
2 = administrator
- X54** = ASCII digit(s) representing the numeric value of the data element read from the event buffer (leading zeros are suppressed)
- X55** = Input 1 - 6
- X56** = On/off  
0 = off  
1 = on
- X57** = Window  
0 = both windows (available only for Freeze and window muting)  
1 = window 1  
2 = window 2
- X58** = Input video format  
1 = RGB  
2 = YUVp  
3 = RGBcVs  
4 = YUVi  
5 = S-video  
6 = Composite  
7 = SDI
- X59** = Test pattern  
0 = off  
1 = color bars  
2 = crosshatch  
3 = 4 x 4 crosshatch  
4 = grayscale  
5 = crop  
6 = ramp  
7 = Alternating pixels  
8 = side-by-side crop  
9 = 4 x 3/16 x 9 film aspect ratio 1.78  
10 = 4 x 3/16 x 9 film aspect ratio 1.85  
11 = 4 x 3/16 x 9 film aspect ratio 2.35
- X60** = Window text position  
0 = none  
1 = bottom left  
2 = bottom center  
3 = bottom right  
4 = top left  
5 = top center  
6 = top right
- X61** = Window text, 16 characters maximum (Can use ASCII characters 32 - 126.)
- X62** = Picture adjustment range  
(0 - 127; default = 64)
- X63** = Scaler resolution  
1 = 640 x 480  
2 = 800 x 600  
3 = 852 x 480  
4 = 1024 x 768  
5 = 1024 x 852  
6 = 1024 x 1024  
7 = 1280 x 768  
8 = 1280 x 1024  
9 = 1360 x 765  
10 = 1365 x 768  
11 = 1366 x 768  
12 = 1365 x 1024  
13 = 1400 x 1050  
14 = 1600 x 1200  
15 = 480p  
16 = 576p  
17 = 720p  
18 = 1080i  
19 = 1080p
- X64** = Detected input signal standard  
0 = none  
1 = NTSC  
2 = PAL  
4 = SECAM  
- = not applicable (occurs when input is set for RGB or YUV)
- X65** = Sharpness (detail) level (0 - 127)

- 
- X67** = Window transition effect type
- 1 = cut
  - 2 = dissolve
  - 3 = soft wipe up
  - 4 = soft wipe down
  - 5 = soft wipe right
  - 6 = soft wipe left
  - 7 = soft wipe center in
  - 8 = soft wipe center out
  - 9 = soft wipe square in
  - 10 = soft wipe square out
  - 11 = soft wipe curtain in
  - 12 = soft wipe curtain out
  - 13 = hard wipe up
  - 14 = hard wipe down
  - 15 = hard wipe right
  - 16 = hard wipe left
  - 17 = hard wipe center in
  - 18 = hard wipe center out
  - 19 = hard wipe square in
  - 20 = hard wipe square out
  - 21 = hard wipe curtain in
  - 22 = hard wipe curtain out
- X68** = Blanking adjustment range (0 - 255 lines)
- X69** = Window preset (1 - 25)
- X70** = Input preset (1 - 128)
- X72** = Scaler refresh rate
- 1 = 50 Hz
  - 2 = 60 Hz
  - 3 = 72 Hz
  - 4 = 96 Hz
  - 5 = 100 Hz
  - 6 = 120 Hz
- X73** = Pixel phase (0-31)
- X74** = Advanced picture settings range  
(±128 auto-sensed value)
- X75** = Window dissolve speed; 0 to 5 seconds in  
0.1 second increments (01 = 0.1 second;  
50 = 5.0 seconds)
- X76** = Internal temperature in degrees Fahrenheit
- X77** = Background image number (01 - 16)
- NOTE** *Images must be named in the format  
Bkgrrn.bmp. nn = 01 - 16).*
- NOTE** *Images must be 24-bit bitmaps. Other  
formats are not supported.*
- X78** = Image/Window shift value (zero location  
is 2048, and limits are ± the output  
resolution)
- X79** = Window size. Windows can be 1/16 the  
size of the output active area.  
Maximum value is the active output  
area.
- X80** = Image size. Image can be 1/16 the size of  
the input active area. Maximum value  
is double the active output area for  
200% zoom.
- X81** = E-mail account user name. Maximum  
length is 31 characters.
- X82** = E-mail account password. Maximum  
length is 31 characters. The MGP  
responds with four asterisks (\*\*\*\*) if a  
password exists. If no password has  
been set, the response is a blank field.

# Software Configuration and Control, cont'd

Command/response table for SIS commands

Command	ASCII Command (host to processor)	Response (processor to host)	Additional description
<b>Input selection</b>			
Set input to window	X55 * X57 !	Out X57 In X55 ↓	Set input source X55 to window X57.
<b>Input video type</b>			
Set input video type	X55 * X58 \	X55 Typ X58 ↓	Set input X55 to format X58.
View video type	X55 \	X58 ↓	View the video type of input X55.
<b>Window muting/unmuting</b>			
Mute window	X57 * 1B	X57 Blk1 ↓	Mute (blank) window X57 using a selected transition effect.
Unmute window	X57 * 0B	X57 Blk0 ↓	Unmute (display) window X57 using a selected transition effect.
View muting status	X57 B	X58 ↓	View the window muting status.
<b>Window priority</b>			
Set priority	X57 * X57 ~	Pri X57 • X57 ↓	Set the priority of the windows to the order entered.
View priority <i>Example:</i>	~ ~	X57 • X57 ↓ 2 1	Display the priority of the windows. Window #2 has priority and will be displayed in front of window #1.
<b>Window transition effect</b>			
Select effect	X57 * 4#	Eff X57 ↓	Select window transition effect X57.
View effect	4#	X57 ↓	View the current window transition effect.
<b>Window effect duration</b>			
Select speed	X75 * 5#	Dur X75 ↓	Set the transition effect duration to X75.
View speed	5#	X75 ↓	View the transition effect duration time.
<b>Color</b>			
Set color to a specific value	X57 * X62 C	X57 Col X62 ↓	Select color value X62 in window X57.
Increment color value	X57 +C	X57 Col X62 ↓	Select the next higher color value.
Decrement color value	X57 -C	X57 Col X62 ↓	Select the next lower color value.
View color setting	X57 C	X57 ↓	Show the current color setting.



## Command/response table for SIS commands (continued)

Command	ASCII Command (host to processor)	Response (processor to host)	Additional description
<b>Tint</b>			
Set tint to a specific value	$\text{X57} * \text{X62} \text{ T}$	$\text{X57} \text{ Tin } \text{X62} \downarrow$	Select tint value $\text{X62}$ in window $\text{X57}$ .
Increment tint value	$\text{X57} + \text{T}$	$\text{X57} \text{ Tin } \text{X62} \downarrow$	Select next higher tint value in window $\text{X57}$ .
Decrement tint value	$\text{X57} - \text{T}$	$\text{X57} \text{ Tin } \text{X62} \downarrow$	Select next lower tint value in window $\text{X57}$ .
View tint setting	$\text{X57} \text{ T}$	$\text{X62} \downarrow$	Show the current tint setting.
<b>Contrast</b>			
Set contrast to a specific value	$\text{X57} * \text{X62} \wedge$	$\text{X57} \text{ Con } \text{X62} \downarrow$	Select contrast value $\text{X62}$ in window $\text{X57}$ .
Increment contrast value	$\text{X57} + \wedge$	$\text{X57} \text{ Con } \text{X62} \downarrow$	Select the next higher contrast value.
Decrement contrast value	$\text{X57} - \wedge$	$\text{X57} \text{ Con } \text{X62} \downarrow$	Select the next lower contrast value.
View contrast setting	$\text{X57} \wedge$	$\text{X62} \downarrow$	Show the current contrast setting.
<b>Brightness</b>			
Set brightness to a specific value	$\text{X57} * \text{X62} \text{ Y}$	$\text{X57} \text{ Brt } \text{X62} \downarrow$	Select brightness value $\text{X62}$ in window $\text{X57}$ .
Increment brightness value	$\text{X57} + \text{Y}$	$\text{X57} \text{ Brt } \text{X62} \downarrow$	Select the next higher brightness value.
Decrement brightness value	$\text{X57} - \text{Y}$	$\text{X57} \text{ Brt } \text{X62} \downarrow$	Select the next lower brightness value.
View brightness setting	$\text{X57} \text{ Y}$	$\text{X62} \downarrow$	Show the current brightness setting.
<b>Detail filter</b>			
Set detail level	$\text{X57} * \text{X66} \text{ D}$	$\text{X57} \text{ Det } \text{X66} \downarrow$	Set the detail level to $\text{X66}$ in window $\text{X57}$ .
Increment detail level	$\text{X57} + \text{D}$	$\text{X57} \text{ Det } \text{X66} \downarrow$	Select the next higher detail level.
Decrement detail level	$\text{X57} - \text{D}$	$\text{X57} \text{ Det } \text{X66} \downarrow$	Select the next lower detail level.
View detail value	$\text{X57} \text{ D}$	$\text{X66} \downarrow$	Show the current detail level setting.
<b>Horizontal shift (window)</b>			
Set horizontal shift to a specific value	$1 * \text{X57} * \text{X78} \text{ H}$	$\text{X57} \text{ Whp } \text{X78} \downarrow$	Set horizontal center of window $\text{X57}$ to $\text{X78}$ .
Shift window right	$1 * \text{X57} + \text{H}$	$\text{X57} \text{ Whp } \text{X78} \downarrow$	Shift window $\text{X57}$ right.
Shift window left	$1 * \text{X57} - \text{H}$	$\text{X57} \text{ Whp } \text{X78} \downarrow$	Shift window $\text{X57}$ left.
View horizontal shift setting	$1 * \text{X57} \text{ H}$	$\text{X78} \downarrow$	Show the current horizontal centering setting for window $\text{X57}$ .

# Software Configuration and Control, cont'd

Command/response table for SIS commands (continued)

Command	ASCII Command (host to processor)	Response (processor to host)	Additional description
<b>Horizontal shift (image)</b>			
Set horizontal shift to a specific value	2 * $\text{X57}$ * $\text{X78}$ H	$\text{X57}$ lhp $\text{X78}$ $\downarrow$	Set the horizontal centering of the image in window $\text{X57}$ to $\text{X78}$ .
Shift image right	2 * $\text{X57}$ + H	$\text{X57}$ lhp $\text{X78}$ $\downarrow$	Shift the image in window $\text{X57}$ right.
Shift image left	2 * $\text{X57}$ - H	$\text{X57}$ lhp $\text{X78}$ $\downarrow$	Shift the image in window $\text{X57}$ left.
View horizontal shift setting	2 * $\text{X57}$ H	$\text{X62}$ $\downarrow$	Show the current horizontal centering setting for the image in window $\text{X57}$ .
<b>Vertical shift (window)</b>			
Set vertical shift to a specific value	1 * $\text{X57}$ * $\text{X78}$ /	$\text{X57}$ Wvp $\text{X78}$	Set the vertical centering of window to $\text{X78}$ .
Shift window up	1 * $\text{X57}$ + /	$\text{X57}$ Wvp $\text{X78}$ $\downarrow$	Shift window $\text{X57}$ up.
Shift window down	1 * $\text{X57}$ - /	$\text{X57}$ Wvp $\text{X78}$ $\downarrow$	Shift window $\text{X57}$ down.
View vertical shift setting	1 * $\text{X57}$ /	$\text{X78}$ $\downarrow$	Show the current vertical centering setting for window $\text{X57}$ .
<b>Vertical shift (image)</b>			
Set vertical shift to a specific value	2 * $\text{X57}$ * $\text{X78}$ /	$\text{X57}$ lvp $\text{X78}$ $\downarrow$	Set the vertical centering of the image in window $\text{X57}$ to $\text{X78}$ .
Shift image up	2 * $\text{X57}$ + /	$\text{X57}$ lvp $\text{X78}$ $\downarrow$	Shift the image in window $\text{X57}$ up.
Shift image down	2 * $\text{X57}$ - /	$\text{X57}$ lvp $\text{X78}$ $\downarrow$	Shift the image in window $\text{X57}$ down.
View vertical shift setting	2 * $\text{X57}$ /	$\text{X78}$ $\downarrow$	Show the current vertical centering setting for the image in window $\text{X57}$ .
<b>Horizontal size (window)</b>			
Set horizontal size to a specific value	1 * $\text{X57}$ * $\text{X79}$ :	$\text{X57}$ Whs $\text{X79}$ $\downarrow$	Set the horizontal sizing of window $\text{X57}$ to $\text{X79}$ .
Increase horizontal size setting	1 * $\text{X57}$ + :	$\text{X57}$ Whs $\text{X79}$ $\downarrow$	Make window $\text{X57}$ wider.
Decrease horizontal size setting	1 * $\text{X57}$ - :	$\text{X57}$ Whs $\text{X79}$ $\downarrow$	Make window $\text{X57}$ narrower.
View horizontal size setting	1 * $\text{X57}$ :	$\text{X79}$ $\downarrow$	Show the current horizontal size setting for window $\text{X57}$ .

## Command/response table for SIS commands (continued)

Command	ASCII Command (host to processor)	Response (processor to host)	Additional description
<b>Vertical size (window)</b>			
Set vertical size to a specific value	1 * $\boxed{X57}$ * $\boxed{X79}$ ;	$\boxed{Wvs}$ $\boxed{X79}$ ↓	Set the vertical sizing of window $\boxed{X57}$ to $\boxed{X79}$ .
Increase vertical size setting	1 * $\boxed{X57}$ + ;	$\boxed{X57}$ $\boxed{Wvs}$ $\boxed{X79}$ ↓	Make window $\boxed{X57}$ taller.
Decrease vertical size setting	1 * $\boxed{X57}$ - ;	$\boxed{X57}$ $\boxed{Wvs}$ $\boxed{X79}$ ↓	Make window $\boxed{X57}$ shorter.
View vertical size setting	1 * $\boxed{X57}$ ;	$\boxed{X79}$ ↓	Show the current vertical size setting for window $\boxed{X57}$ .
<b>Horizontal size (image)</b>			
Set horizontal size to a specific value	2 * $\boxed{X57}$ * $\boxed{X80}$ :	$\boxed{X57}$ $\boxed{lhs}$ $\boxed{X80}$ ↓	Set the horizontal sizing of image in window $\boxed{X57}$ to $\boxed{X80}$ .
Increase horizontal size setting	2 * $\boxed{X57}$ + :	$\boxed{X57}$ $\boxed{lhs}$ $\boxed{X80}$ ↓	Make the image in window $\boxed{X57}$ wider.
Decrease horizontal size setting	2 * $\boxed{X57}$ - :	$\boxed{X57}$ $\boxed{lhs}$ $\boxed{X80}$ ↓	Make the image in window $\boxed{X57}$ narrower.
View horizontal size setting	2 * $\boxed{X57}$ ;	$\boxed{X80}$ ↓	Show the current horizontal size setting for image in window $\boxed{X57}$ .
<b>Vertical size (image)</b>			
Set vertical size to a specific value	2 * $\boxed{X57}$ * $\boxed{X80}$ ;	$\boxed{X57}$ $\boxed{ivs}$ $\boxed{X80}$ ↓	Set the vertical sizing of image in window $\boxed{X57}$ to $\boxed{X80}$ .
Increase vertical size setting	2 * $\boxed{X57}$ + ;	$\boxed{X57}$ $\boxed{ivs}$ $\boxed{X80}$ ↓	Make the image in window $\boxed{X57}$ taller.
Decrease vertical size setting	2 * $\boxed{X57}$ - ;	$\boxed{X57}$ $\boxed{ivs}$ $\boxed{X80}$ ↓	Make the image in window $\boxed{X57}$ shorter.
View vertical size setting	2 * $\boxed{X57}$ ;	$\boxed{X80}$ ↓	Show current vertical size setting for image in window $\boxed{X57}$ .
<b>Window size and position</b>			
Set window size and position	$\boxed{Esc}$ $\boxed{X57}$ , $\boxed{X78}$ * $\boxed{X78}$ * $\boxed{X79}$ * $\boxed{X79}$ XY ←	$\boxed{Wxy}$ $\boxed{X57}$ , $\boxed{X78}$ * $\boxed{X78}$ * $\boxed{X79}$ * $\boxed{X79}$ ↓	Set the size and position of window $\boxed{X57}$ .
View window size and position	$\boxed{Esc}$ $\boxed{X57}$ XY	$\boxed{X57}$ , $\boxed{X78}$ * $\boxed{X78}$ * $\boxed{X79}$ * $\boxed{X79}$ ↓	View the size and position of window $\boxed{X57}$ .
<b>NOTE</b> The variables must be entered in the following order: window number, horizontal position, vertical position, horizontal size, vertical size.			
<b>Image size and position</b>			
Set image size and position	$\boxed{Esc}$ $\boxed{X57}$ , $\boxed{X78}$ * $\boxed{X78}$ * $\boxed{X79}$ * $\boxed{X79}$ IY ←	$\boxed{Ixy}$ $\boxed{X57}$ , $\boxed{X78}$ * $\boxed{X78}$ * $\boxed{X79}$ * $\boxed{X79}$ ↓	Set the size and position of the image in window $\boxed{X57}$ .
View image size and position	$\boxed{Esc}$ $\boxed{X57}$ IY	$\boxed{X57}$ , $\boxed{X78}$ * $\boxed{X78}$ * $\boxed{X79}$ * $\boxed{X79}$ ↓	View the size and position of the image in window $\boxed{X57}$ .
<b>NOTE</b> The variables must be entered in the following order: window number, horizontal position, vertical position, horizontal size, vertical size.			

Command/response table for SIS commands (continued)

Command	ASCII Command (host to processor)	Response (processor to host)	Additional description
<b>Zoom mode (window)</b>			
Zoom in	1 * <b>X57</b> + {	<b>X57</b> Wzm ↓	Increase the size of window <b>X57</b> while keeping the aspect ratio constant.
Zoom out	1 * <b>X57</b> - {	<b>X57</b> Wzm ↓	Decrease the size of window <b>X57</b> while keeping the aspect ratio constant.
<b>Zoom mode (image)</b>			
Zoom in	2 * <b>X57</b> + {	<b>X57</b> Izm ↓	Increase the size of the image in window <b>X57</b> while keeping the aspect ratio constant.
Zoom out	2 * <b>X57</b> - {	<b>X57</b> Izm ↓	Decrease the size of the image in window <b>X57</b> while keeping the aspect ratio constant.
<b>Window presets</b>			
Recall preset without input	1 * <b>X69</b> .	Rpr 1 * <b>X69</b> ↓	Recall window preset <b>X69</b> without input settings.
Recall preset with input	2 * <b>X69</b> .	Rpr 2 * <b>X69</b> ↓	Recall window preset <b>X69</b> with input settings.
Save window preset	2 * <b>X69</b> ,	Spr 2 * <b>X69</b> ↓	Save the current window settings as a preset at location <b>X69</b> .
<b>Window preset naming</b> (Not viewable from unit LCD screen. Viewable through Web page and SIS commands.)			
Write window name preset	<b>Esc</b> <b>X69</b> , <b>X61</b> NP←	Nmp <b>X69</b> , <b>X61</b> ↓	Give the window preset at location <b>X69</b> the name <b>X61</b> .
Read window name preset	<b>Esc</b> <b>X69</b> NP←	<b>X61</b> ↓	View the name of window preset <b>X69</b> .
<b>Input presets</b>			
Recall input preset	3 * <b>X57</b> * <b>X70</b> .	Rpr 3 * <b>X70</b> ↓	Recall input preset <b>X70</b> to window <b>X57</b> .
Save input preset	3 * <b>X57</b> * <b>X70</b> ,	Spr 3 * <b>X70</b> ↓	Save input settings in window <b>X57</b> to preset location <b>X70</b> .
<b>Input naming</b>			
Write input name	<b>Esc</b> <b>X55</b> , <b>X61</b> NI←	Nmi <b>X55</b> , <b>X61</b> ↓	Create a text label containing name <b>X61</b> for input <b>X55</b> .
Read input name	<b>Esc</b> <b>X55</b> NI←	<b>X61</b> ↓	View the contents of the name label for input <b>X55</b> .

**Command/response table for SIS commands (continued)**

<b>Command</b>	<b>ASCII Command (host to processor)</b>	<b>Response (processor to host)</b>	<b>Additional description</b>
<b>Vertical start</b>			
Set vertical start to a specific value	* $\text{X68}$ (	$\text{Vst } \text{X55} * \text{X68} \downarrow$	Set the vertical location of first active pixel in the window displaying input $\text{X55}$ to $\text{X68}$ .
Increment vertical start value	$\text{X55} + ($	$\text{Vst } \text{X55} * \text{X68} \downarrow$	Select the next higher vertical start position after $\text{X68}$ .
Decrement vertical start value	$\text{X55} - ($	$\text{Vst } \text{X55} * \text{X68} \downarrow$	Select the next lower vertical start position before $\text{X68}$ .
View vertical start setting	$\text{X55} ($	$\text{X68} \downarrow$	Show the current vertical start setting for the window displaying input $\text{X57}$ .
<b>Horizontal start</b>			
Set horizontal start to a specific value	$\text{X55} * \text{X68} )$	$\text{Hst } \text{X55} * \text{X68} \downarrow$	Set the horizontal location of the first active pixel for input $\text{X55}$ to $\text{X68}$ .
Increment horizontal start value	$\text{X55} + )$	$\text{Hst } \text{X55} * \text{X68} \downarrow$	Select the next higher horizontal start position after $\text{X68}$ .
Decrement horizontal start value	$\text{X55} - )$	$\text{Hst } \text{X55} * \text{X68} \downarrow$	Select the next lower horizontal start position before $\text{X68}$ .
View horizontal start setting	$\text{X55} )$	$\text{X68} \downarrow$	Show the current horizontal start setting for input $\text{X55}$ .
<b>Pixel phase (Available only for RGB and YUVp input signals)</b>			
Set pixel phase to a specific value	$\text{X57} * \text{X73} \text{ U}$	$\text{X57} \text{ Phs } \text{X55} * \text{X73} \downarrow$	Set the pixel phase value for the input in window $\text{X57}$ to $\text{X73}$ .
Increment pixel phase value	$\text{X57} + \text{U}$	$\text{X57} \text{ Phs } \text{X55} * \text{X73} \downarrow$	Select the next higher pixel phase value after $\text{X73}$ .
Decrement pixel phase value	$\text{X57} - \text{U}$	$\text{X57} \text{ Phs } \text{X55} * \text{X73} \downarrow$	Select the next lower pixel phase value before $\text{X73}$ .
View pixel phase setting	$\text{X57} \text{ U}$	$\text{X73} \downarrow$	Show the current pixel phase setting for the input in window $\text{X57}$ .
<b>Total pixels (Available only for RGB and YUVp input signals)</b>			
Set total pixels to a specific value	$\text{X55} * \text{X74} * 11\#$	$\text{TpX } \text{X55} * \text{X74} \downarrow$	Set the total pixels value for input $\text{X55}$ to $\text{X74}$ .
Increment total pixels value	$\text{X55} + 11\#$	$\text{TpX } \text{X55} * \text{X74} \downarrow$	Select the next higher total pixels value after $\text{X74}$ .
Decrement total pixels value	$\text{X55} - 11\#$	$\text{TpX } \text{X55} * \text{X74} \downarrow$	Select the next lower total pixels value before $\text{X74}$ .

# Software Configuration and Control, cont'd

Command/response table for SIS commands (continued)

Command	ASCII Command (host to processor)	Response (processor to host)	Additional description
<b>Total pixels, continued</b>			
View total pixels setting	X55 * 11#	X74 ↓	Show the current total pixels setting for input X55.
<b>Active pixels</b>			
Set active pixels to a specific value	X55 * X74 * 12#	Apx X55 * X74 ↓	Set active pixels value for input X55 to X74.
Increment active pixels value	X55 + 12#	Apx X55 * X74 ↓	Select the next higher active pixels value after X74.
Decrement active pixels value	X55 - 12#	Apx X55 * X74 ↓	Select the next lower active pixels value before X74.
View active pixels setting	X55 * 12#	X74 ↓	Show the current active pixels setting for input X55.
<b>Active lines</b>			
Set active lines to a specific value	X55 * X74 * 13#	Aln X55 * X74 ↓	Set the active lines value for input X55 to X74.
Increment active lines value	X55 + 13#	Aln X55 * X74 ↓	Select the next higher active lines value.
Decrement active lines value	X55 - 13#	Aln X55 * X74 ↓	Select the next lower active lines value.
View active lines setting	X55 * 13#	X74 ↓	Show the current active lines setting for input X55.
<b>Scaler output resolution and scan rate</b>			
Set the output resolution and scan rate	X63 * X72 =	Rte X63 * X72 ↓	Set the scaler output resolution to X63 and the scan rate to X72.
View the output settings	=	Rte X63 * X72 ↓	Show the current output resolution and scan rate settings.
<b>Test Pattern</b>			
Select test pattern	X59 J	Tst X59 ↓	Select test pattern X59.
View test pattern	J	X59 ↓	Show the current test pattern setting.
<b>Freeze</b>			
Enable	X57 * 1F	X57 Frz1 ↓	Freeze the video image.
Disable	X57 * 0F	X57 Frz0 ↓	Unfreeze the video image.
View status	X57 F	X56 ↓	Show the freeze status.

## Command/response table for SIS commands (continued)

Command	ASCII Command (host to processor)	Response (processor to host)	Additional description
<b>Executive mode</b>			
Enable executive mode	1X	Exe1 ↵	Lock front panel control; allow RS-232/422 adjustments only.
Enable executive mode 2	2X	Exe2 ↵	Lock all front panel controls including input buttons; allow RS-232/422 control only.
Disable	0X	Exe0 ↵	Unlock all front panel controls.
View executive mode status	X	X66 ↵	Show executive mode status.
<b>Special functions</b>			
Output polarity	[X] * 1#	Pol [X] ↵	Set output polarity [X]: 0 = H-/V- (default) 1 = H-/V+ 2 = H+/V- 3 = H+/V+
View polarity setting	1#	[X] ↵	View the current output polarity setting.
Output sync format	[X] * 2#	Syn [X] ↵	Set output sync format [X]: 1 = RGBHV (Default) 2 = RGsB 3 = YUV bi-level 4 = YUV tri-level
View sync format setting	2#	[X] ↵	View current output sync format setting.
Blue screen	[X] * 3#	Blu [X] ↵	Turn Blue mode on/off. [X] is: 0 = off (default) 1 = on
View Blue mode setting	3#	[X] ↵	View the current Blue Screen mode.
Text position	X60 * 6#	Tlc X60 ↵	Set location of text box to X60.
View text position setting	6#	X60 ↵	View the current text position [X]. [X] is:
Text size	[X] * 10#	Tsz [X] ↵	Set the size of the label text to [X]. [X] is: 1 = small 2 = medium 3 = large
View text size setting	10#	[X] ↵	View the current text size setting.

## Command/response table for SIS commands (continued)

Command	ASCII Command (host to processor)	Response (processor to host)	Additional description
<b>Special functions, continued</b>			
Text border color	<code>X57 * X1 * 14#</code>	<code>X57 Txb X1 ↓</code>	Set the color of the text border in window <code>X57</code> to <code>X1</code> . <code>X1</code> is: 0 = off 1 = Red 2 = Green 3 = Blue 4 = White 5 = Magenta 6 = Cyan 7 = Yellow 8 = Black 9 = Translucent
View text border color setting	<code>X57 * 14#</code>	<code>X1 ↓</code>	View the current text border color.
Text color	<code>X57 * X1 * 16#</code>	<code>X57 Txc X1 ↓</code>	Set the color of the text in window <code>X57</code> to <code>X1</code> .: 1 = Red 2 = Green 3 = Blue 4 = White 5 = Magenta 6 = Cyan 7 = Yellow 8 = Black
View text color setting	<code>X57 * 16#</code>	<code>X1 ↓</code>	View current text color in window <code>X57</code> .
Text background color	<code>X57 * X1 * 17#</code>	<code>X57 Tbc X1 ↓</code>	Change the background color of the text label in window <code>X57</code> to <code>X1</code> .: 0 = off 1 = Red 2 = Green 3 = Blue 4 = White 5 = Magenta 6 = Cyan 7 = Yellow 8 = Black 9 = Translucent
View text background color setting	<code>X57 * 17#</code>	<code>X1 ↓</code>	View the current background color of the text label in window <code>X57</code> .



## Command/response table for SIS commands (continued)

Command	ASCII Command (host to processor)	Response (processor to host)	Additional description
<b>Special functions, continued</b>			
Window border color	$\text{X57} * \text{XI} * 9\#$	$\text{X57}$ Brd $\text{XI} \downarrow$	Set the border color for window $\text{X57}$ to $\text{XI}$ : 0 = none (default) 1 = red 2 = green 3 = blue 4 = white 5 = magenta 6 = cyan 7 = yellow 8 = black
View window border color setting	$\text{X57} * 9\#$	$\text{XI} \downarrow$	View current border color for window $\text{X57}$ .
<b>Background image</b>			
Save background image	1 * $\text{X77} * 15\#$	ImS $\text{X77} \downarrow$	Save current background image $\text{X77}$ to memory.
Recall background image	2 * $\text{X77} * 15\#$	Imr $\text{X77} \downarrow$	Recall image $\text{X77}$ from memory to display.
View current image number	15#	$\text{X77} \downarrow$	View the currently displayed background image number.
<b>Background color</b>			
Background color	$\text{XI} * 8\#$	Bkg $\text{XI} \downarrow$	Set the display background color to $\text{XI}$ : 0 = none (default) 1 = red 2 = green 3 = blue 4 = white 5 = magenta 6 = cyan 7 = yellow 8 = background image 9 = user-defined color
View background color setting	8#	$\text{XI} \downarrow$	View the current background color setting.

## Command/response table for IP control port commands

Command	ASCII (Telnet) (host to processor)	URL Encoded (Web) (host to processor)	Response (processor to host)	Additional description
<b>Background color, continued</b>				
Set user-defined color levels	[X1] * [X1] * [X1] * 22#	Ubk [X1] * [X1] * [X1] * [X1] ↵		Set the red, green, and blue values for the user-defined color. [X1] = 0-255 level scale.
<i>Example:</i>	50 * 100 * 150 * 22#	Ubk 50 * 100 * 150 ↵		The red, green, and blue levels for the user-defined colors are 50, 100, and 150, respectively.
View user-defined color levels	22#	Ubk [X1] * [X1] * [X1] * [X1] ↵		Show the red, green, and blue levels for the user-defined colors.
<b>Film mode</b>				
Enable Film mode	[X55] * 1 * 18#	[X55] Flm1 ↵		Enable Film mode. (Auto-senses for 3:2 or 2:2 pull-down.)
Disable Film mode	[X55] * 0 * 18#	[X55] Flm0 ↵		Disable Film mode.
View Film mode status	[X55] * 18#	0 ↵ (off) or 1 ↵ (on)		View the current Film mode setting.
<b>Auto Image</b>				
Run Auto Image	[X57] * 55#	Aut [X57] ↵		Perform Auto Image adjustment on window [X57].
<b>Bi-directional serial data port</b>				
Send data string	[Esc] [X1] * [X17] * [X20] * [X21] RS ← [X2] W [X1] %2A[X17] %2A[X20] %2A[X21] RS   [X2]			Response from command ↵
<b>NOTE</b>				
[X1] = port number (01-99).				
[X17] = time in tens of milliseconds that the MGP will wait until receipt of the first response character before terminating the command (default = 10 = 100 ms, max. = 32767).				
[X20] = time in tens of ms that the MGP will wait between characters being received via a serial port before terminating the current command or receive operation (default = 2 = 20 ms, max. = 32767).				
[X21] = #L or #D. The letter parameter is case sensitive (requires capital D or capital L).				
L = Length of the message to be received.				
D = Delimiter value				
# = byte count (for L) or a single ASCII character expressed in decimal form (for D).				
Byte count # can be from 0 to 32767, default = 0. The ASCII decimal # can be from 0 to 00255, default = the byte count. A 3-byte length = 3L.				
A delimiter of ASCII 0A = 10D.				
The response includes leading zeros.				
[X2] = command data section. For Web encoding for [X2], be sure to convert nonalphanumeric characters to hex numbers.				
<i>Example:</i>	[Esc] 05*4*7*3L RS ←<data>•		W05%2A4%2A7%2A3L RS   <data>	Response from command ↵
<b>NOTE</b>				
The * [X17] * [X20] * [X21] sequence is optional. If [X17] and [X20] are not specified, the default values are used.				

## Command/response table for IP control port commands (continued)

Command	ASCII (Telnet) (host to processor)	URL Encoded (Web) (host to processor)	Response (processor to host)	Additional description
<b>Bi-directional serial data port, continued</b>				
Configure serial port parameters <sup>24</sup>	<code>[Esc] X1 * X25 , X26 , X27 , X28 CP ←</code> <code>W X1 %2A X25 %2A X26 %2A X27 %2A X28 CP  </code>		<code>Cpn X1 • Ccp X25 , X26 , X27 , X28 ↓</code>	Set baud rate (X25), parity (X26), data bits (X27), and stop bits (X28) for port X1.
View serial port parameters	<code>[Esc] X1 CP ←</code>	<code>W X1 CP  </code>	<code>X25 , X26 , X27 , X28 ↓</code>	Show the serial port parameters.
Configure mode <sup>24</sup>	<code>[Esc] X1 * X29 CY ←</code>	<code>W X1 %2A CY  </code>	<code>Cpn X1 • Cty X29 ↓</code>	Select port type X29 for port X1: 0 = RS-232 1 = RS-422
View mode	<code>[Esc] X1 CP ←</code>	<code>W X1 CY  </code>	<code>X29 ↓</code>	
Configure flow control <sup>24</sup>	<code>[Esc] X1 * X30 , X31 CF ←</code>	<code>W X1 %2A X30 %2C X31 CF  </code>	<code>Cpn X1 • Cf X30 , X31 ↓</code>	Set flow control X30 and data pacing rate X31 for port X1. For X30: H = hardware S = software N = none (default) X31 = number of milliseconds between bytes. Range is 0000-1000; default is 0 ms.
View flow control	<code>[Esc] X1 CF ←</code>	<code>W X1 Cf  </code>	<code>X30 , X31 ↓</code>	Show flow control rates for port X1.
Configure receive timeout <sup>24</sup>	<code>[Esc] X1 * X17 * X20 * X23 * X21 CE ←</code> <code>W X1 %2A X17 %2A X20 %2A X23 %2A X21 CE  </code>		<code>Cpn X1 • Cce X17 , X20 , X23 , X21 ↓</code>	Set the time for port X1 to wait for first response character before timing out. X17 = waiting time in tens of ms until receipt of the first response character. X20 = waiting time in tens of ms between characters. X23 = priority status for port X1 receiving timeouts. 0 = Use <i>Send data string</i> command parameters (default). 1 = Use <i>Configure receive timeout</i> command parameters. Response includes leading zeros.
View receive timeout	<code>[Esc] X1 CE ←</code>	<code>W X1 CE  </code>	<code>X17 , X20 , X23 , X21 ↓</code>	

# Software Configuration and Control, cont'd

## Command/response table for IP control port commands (continued)

Command	ASCII (Telnet) (host to processor)	URL Encoded (Web) (host to processor)	Response (processor to host)	Additional description
<b>Ethernet data port</b>				
Set current connection port timeout	<code>[Esc] 0 * [X51] TC ←</code>	<code>W 0 %2A [X51] TC  </code>	<code>Pti 0 * [X51] ←</code>	[X51] = number of seconds (in tens of seconds) before timeout on IP connections.
View current connection port timeout	<code>[Esc] 0TC ←</code>	<code>W 0TC  </code>	<code>[X51] ←</code>	
Set global IP port timeout	<code>[Esc] 1 * [X51] TC ←</code>	<code>W 1%2A [X51] TC  </code>	<code>Pti1 * [X51] ←</code>	
View global IP port timeout	<code>[Esc] 1TC ←</code>	<code>W 1TC  </code>	<code>[X51] ←</code>	
<b>NOTE</b> An asterisk (*) after the version number indicates which version is currently running. A caret (^) indicates bad checksum/invalid load. Question marks (??) indicate version not loaded.				
<b>Firmware version requests</b>				
Query firmware version	<code>Q or 1Q</code>	<code>Q or 1Q</code>	<code>[X11] ←</code>	Show the processor's firmware version number ([X11]) to two decimal places. Gives the number of the currently running version of the user-updatable firmware.
Query verbose version information	<code>0Q</code>	<code>0Q</code>	<code>Ver01* [X11] ←</code> <code>Sum of responses from 2Q-3Q-4Q ←</code>	<i>With tagged response – verbose modes 2 and 3:</i> Show bootstrap, factory-installed, and updated firmware versions. (See 2Q, 3Q, and 4Q, below.)
<i>Example:</i>	<code>1Q</code>	<code>1Q</code>	<code>Ver00 * Sum of responses from 2Q-3Q-4Q ←</code> 1.01	<i>With tagged response – verbose modes 2 and 3:</i>
Query bootstrap version	<code>2Q</code>	<code>2Q</code>	<code>[X11] ←</code>	The bootstrap firmware is not user-replaceable, but you may need this information for troubleshooting.
<i>Example:</i>	<code>2Q</code>	<code>2Q</code>	<code>Ver02 * [X11] ←</code> 0.06	<i>With tagged response – verbose modes 2 and 3:</i>

## Command/response table for IP control port commands (continued)

Command	ASCII (Telnet) (host to processor)	URL Encoded (Web) (host to processor)	Response (processor to host)	Additional description
<b>Firmware version requests, continued</b>				
Query factory firmware version	3Q	3Q	<b>X11</b> (plus web ver.-desc-UL date/time) ↓	Factory-installed firmware is not user-replaceable. This firmware was installed at the factory; if is the version the processor reverts to after a mode 1 reset (see chapter 3).
<i>Example:</i>	3Q	3Q	<i>With tagged response – verbose modes 2 and 3:</i> Ver03 * <b>X11</b> (plus Web version–description–UL date/time) ↓ 1.00(1.07-MGP462 Series -Wed, 16 Jan 2003 03:28:10 GMT)	In this example, the factory firmware version is 1.00, also known as the kernel version 1.07, for the MGP 462, dated 16 January, 2003.
Query updated firmware version	4Q	4Q	<b>X11</b> ↓	Use this command to find out which version of the firmware, if any, was uploaded into the processor after it left the factory.
<i>Example:</i>	4Q	4Q	<i>With tagged response – verbose modes 2 and 3:</i> Ver04 * <b>X11</b> (plus Web version–description–UL date/time) ↓ 1.01 * (1.22-MGP462 Series -Mon, 17 Jan 2005 17:03:46 GMT)	In this example, the factory firmware version is 1.01, a.k.a. kernel version 1.22, for MGP 462, dated 17 January, 2005.
<b>Information requests</b>				
Request processor part number	N	N	60-XXX-XX ↓	Show processor part number. MGP 462 is 60-623-01. MGP 462D (SDI) is 60-623-02.
			<i>With tagged response – verbose modes 2 and 3:</i> Pno 60-623-01 or Pno 60-623-02 ↓	

# Software Configuration and Control, cont'd

## Command/response table for IP control port commands (continued)

Command	ASCII (Telnet) (host to processor)	URL Encoded (Web) (host to processor)	Response (processor to host)	Additional description
<b>Information requests, continued</b>				
Request model name	1I	1I	MGP 462 ↓ With tagged response – verbose modes 2 and 3: Inf01 * MGP 462 or INF01 * MGP 462D ↓	Show processor model name.
Request model description	2I	2I	Multi-Graphic Processor With tagged response – verbose modes 2 and 3: Inf02 * Multi-Graphic Processor ↓	Show type of unit.
Request system memory usage	3I	3I	# Bytes Used out of #KBytes ↓	Show amount of memory used and total available memory for system operations.
Request user memory usage	4I	4I	Inf03 * n Bytes used out of n KBytes ↓ # Bytes used out of #Kbytes ↓	Show amount of user memory used and total available user memory.
Request general information	X57 * I/i	Chn X55 • Typ X59 • Std X64 • Blk X56 ↓	With tagged response – verbose modes 2 and 3: Inf04 * n Bytes used out of n KBytes ↓	
View internal temperature	20S	X76 ↓	With tagged response – Verbose modes 2 and 3: Sts20 * X76 ↓	Show input number, video type, signal standard, and blanking status. Show internal temperature in degrees Fahrenheit.
<b>Event Control</b>				
Read event buffer memory <sup>27</sup>	Esc X35, X36, X37, X38 E ←	W X35 X36 X37 X38 E	X54 ↓	Read the contents of a specific section of a memory buffer for event number X54.
Write event to memory buffer <sup>24 27</sup>	Esc X35, X36, X37, X38 E ←	W X35 X36 X37 X38 E	EWT X35, X39 ↓	Write event X35 to buffer X36, offset by X37. Include data X39, size X38.

## Command/response table for IP control port commands (continued)

Command	ASCII (Telnet)	URL Encoded (Web) (host to processor)	Response (host to processor)	Additional description
<b>Event control, continued</b>				
Read string from event buffer memory <sup>27</sup>	<code>Esc X35, X36, X37, X44 FE←</code>	<code>W X35, X36, X37, X44 FE  </code>	<code>{string} ↓</code>	Show string from event <code>X35</code> , buffer <code>X36</code> , offset by <code>X37</code> , <code>X44</code> bytes.
Write string to event buffer memory <sup>24 27</sup>	<code>Esc X39, X35, X36, X37 FE←</code>	<code>W X39, %2A X35, X36, X37 FE  </code>	<code>Ewr X35, X39 ↓</code>	Write data string <code>X39</code> from event <code>X35</code> , buffer <code>X36</code> , offset by <code>X37</code> .
Start events <sup>24 27</sup>	<code>Esc IAE←</code>	<code>W1AE  </code>	<code>Ego ↓</code>	Initiate all programmed events.
Stop events <sup>24 27</sup>	<code>Esc OAE←</code>	<code>W0AE  </code>	<code>Est ↓</code>	Stop all programmed events.
Read number of events running	<code>Esc AAE←</code>	<code>WAE  </code>	<code>##### ↓</code> <i>With tagged response – verbose modes 2 and 3:</i> <code>Enum##### ↓</code>	
<b>E-mail</b>				
Configure e-mail events <sup>24</sup>	<code>Esc X45, X46, X47 CR←</code>	<code>W X45, X46, X47 CR  </code>	<code>lpr X45, X46, X47 ↓</code>	<code>X45</code> = e-mail event number (1-64) <code>X46</code> = e-mail recipient's address <code>X47</code> = name of e-mail file to be sent (first line of the file = subject; the rest = body of the e-mail).
<i>Example:</i>	<code>Esc 5, jdoe@extron.com, 7.eml CR←</code>	<code>W5%2Cjdoe%40extron%2Exom%2C7%2Eem1 CR  </code>	<code>lpr5,jdoe@extron.com, 7.eml ↓</code>	<i>For e-mail event 5, send file 7.eml to jdoe@extron.com.</i>
Read e-mail events	<code>Esc X45 CR←</code>	<code>W X45 CR  </code>	<code>X46, X47 ↓</code>	
Send e-mail (event)	<code>Esc X45 SM←</code>	<code>W X45 SM  </code>	<code>Eml X45 ↓</code>	

# Software Configuration and Control, cont'd

## Command/response table for IP control port commands (continued)

Command	ASCII (Telnet) (host to processor)	URL Encoded (Web) (host to processor)	Response (processor to host)	Additional description
<b>Mail server setup commands</b>				
Set mail server IP, unit domain name <sup>24</sup>	<b>Esc</b> <b>X14</b> , <b>X15</b> , <b>X81</b> , <b>X82</b> <b>CM</b> ← W <b>X14</b> %2C <b>X15</b> %2C <b>X81</b> %2C <b>X82</b> <b>CM</b>   Ipm • <b>X14</b> , <b>X15</b> , <b>X81</b> , <b>X82</b> ↓			<b>X81</b> = E-mail account user name. Maximum length is 31 characters. <b>X82</b> = E-mail account password. Maximum length is 31 characters. <b>NOTE</b> These parameters are optional.
Read mail server IP, unit domain name	<b>Esc</b> <b>CM</b> ←	W <b>CM</b>	<b>X14</b> , <b>X15</b> , <b>X81</b> , <b>X82</b> ↓	
<b>Web browser specific commands</b>				
Read response from last URL cmd	<b>Esc</b> <b>UB</b> ←	W <b>UB</b>	Response from command ↓	
<b>IP setup commands</b>				
Set unit name <sup>24</sup>	<b>Esc</b> <b>X12</b> <b>CN</b> ←	W <b>X12</b> <b>CN</b>	Ipn • <b>X12</b> ↓	Change the processor's name to one of your choosing ( <b>X12</b> ). The name consists of up to 24 alphanumeric characters (and the minus sign). The first character must be a letter, the last character cannot be a minus sign (hyphen). Case does not matter.
Set unit name to factory default <sup>24</sup>	<b>Esc</b> • <b>CN</b> ←	W %20 <b>CN</b>	Ipn • <b>X49</b> ↓	<b>X49</b> is the name the processor was shipped with: MPG462-##-##-##, a combination of the model name and the last three pairs of the hex numbers in the processor's MAC address (e.g., MGP462-00-02-3d).
Read unit name	<b>Esc</b> <b>CN</b> ←	W <b>CN</b>	<b>X12</b> ↓	<b>X12</b> is the processor's current unit name. <b>X49</b> is its factory default name.
Set time/date <sup>24</sup>	<b>Esc</b> <b>X13</b> <b>CT</b> ←	W <b>X13</b> <b>CT</b>	Ipt • <b>X13</b> ↓	<b>X13</b> is local date and time format. The set format is MM/DD/YY-HH:MM:SS. Example: 11/18/03-10:54:00



## Command/response table for IP control port commands (continued)

Command	ASCII (Telnet) (host to processor)	URL Encoded (Web) (host to processor)	Response (processor to host)	Additional description
<b>IP setup commands, continued</b>				
Read time/date	<b>Esc</b> CT ←	WCT	<b>X13</b> ↓	The <b>Read</b> format is <i>day of week, DD month year HH:MM:SS</i> . <i>Example:</i> Tue, 18 Nov 2003 18:19:33
Set GMT offset <sup>24</sup>	<b>Esc</b> <b>X3</b> CZ ←	W <b>X3</b> CZ	Ipz <b>X3</b> ↓	Set the Greenwich Mean Time (GMT) offset value ( <b>X3</b> ) for the processor's location. GMT offset (-12.00 to +14.00) represents the time difference in hours and minutes (± hh:mm relative to Greenwich, England. The plus sign and leading zero are optional. <i>Example:</i> 5:30 = +05:30
Read GMT offset	CZ ←	W CZ	<b>X3</b> ↓	
Set daylight savings time <sup>24</sup>	<b>Esc</b> <b>X34</b> CX ←	W <b>X34</b> CX	Ipz <b>X34</b> ↓	<b>X34</b> is the Daylight Savings time of day. Daylight Savings Time (DST) is a 1-hour offset that is observed in the USA and parts of Europe and Brazil. For example, California uses GMT -8:00 from April to October and -7:00 GMT from November to March. DST should be turned off in Hawaii, American Samoa, Guam, Puerto Rico, the U.S. Virgin Islands, the eastern time zone part of Indiana, and Arizona (excluding the Navajo Nation). 0 = off/ignore 1 = on
Read daylight savings time	<b>Esc</b> CX ←	WCX	<b>X34</b> ↓	
Set DHCP on <sup>24</sup>	<b>Esc</b> IDH ←	WIDH	Idh1 ↓	
Set DHCP off <sup>24</sup>	0DH ←	W0DH	Idh0 ↓	
View DHCP mode	<b>Esc</b> DH ←	WDH	Idh <b>X5</b> ↓	<b>X5</b> = 0 (off) or 1 (on).
Set IP address <sup>24</sup>	<b>X14</b> CI ←	W <b>X14</b> CI	Ipj • <b>X14</b> ↓	<b>X14</b> = IP address (xxx.xxx.xxx.xxx). Leading zeros in each of the four fields are optional in setting values.

## Command/response table for IP control port commands (continued)

Command	ASCII (Telnet) (host to processor)	URL Encoded (Web) (host to processor)	Response (processor to host)	Additional description
<b>IP setup commands, continued</b>				
Read IP address <sup>24</sup>	<code>[Esc] CI ←</code>	WCI	<code>[X14] ↓</code>	Leading zeros in each of the four fields are suppressed in returned values.
Read hardware address (MAC)	<code>[Esc] CH ←</code>	WCH	<code>[X18] ↓</code>	<code>[X18]</code> = hardware media access control (MAC) address (xx-xx-xx-xx-xx-xx).
Set subnet mask <sup>24</sup>	<code>[Esc] [X19] CS ←</code>	W [X19]CS	Ips • [X19] ↓	<code>[X19]</code> = subnet mask (xxx.xxx.xxx.xxx). Syntax is the same as for IP addresses. Leading zeros are optional in setting values.
Read subnet mask	<code>[Esc] CS ←</code>	WCS	<code>[X19] ↓</code>	Leading zeros are suppressed.
Set gateway IP address <sup>24</sup>	<code>[Esc] [X14] CG ←</code>	W [X14]CG	Ipg • [X14] ↓	<code>[X14]</code> = IP address (xxx.xxx.xxx.xxx). Leading zeros are optional.
Read gateway IP address	<code>[Esc] CG ←</code>	WCG	<code>[X14] ↓</code>	
Set administrator password <sup>24</sup>	<code>[Esc] [X33] CA ←</code>	W [X33]CA	Ipa • [X33] ↓	Set the administrator access password. <code>[X33]</code> is 4-12 alphanumeric characters.) The password is case sensitive. Special characters (spaces or symbols) are not allowed.
Clear administrator password <sup>24</sup>	<code>[Esc] • CA ←</code>	W%20CA	Ipa • ↓	Clear/remove all passwords (administrator and user).
<b>NOTE</b> A user password cannot be assigned if an administrator password does not exist. Entering a password when the MGP462 has not been configured yields an E14 response from the processor. If the administrator password is cleared (removed), the user password is also removed.				
Read administrator password	<code>[Esc] CA ←</code>	WCA	<code>[X33] ↓</code>	
Set user password <sup>14 24</sup>	<code>[Esc] [X33] CU ←</code>	W [X33]CU	Ipu • [X33] ↓	Set the user password. <code>[X33]</code> is 4-12 alphanumeric characters.) The password is case sensitive. Special characters (spaces or symbols) are not allowed.
<b>NOTE</b> A user password cannot be assigned if an administrator password does not exist.				

## Command/response table for IP control port commands (continued)

Command	ASCII (Telnet) (host to processor)	URL Encoded (Web) (host to processor)	Response (processor to host)	Additional description
<b>IP setup commands, continued</b>				
Clear user password <sup>24</sup>	<b>Esc</b> • CU ←	W%20CU	Ipu • ↓	This clears the user password only.
Read user password <sup>24</sup>	<b>Esc</b> CU ←	WCU	<b>X33</b> ↓	
Set Verbose mode <sup>24</sup>	<b>Esc</b> <b>X22</b> CV ←	W <b>X22</b> CV	<b>X22</b> ↓	Enable or disable the Verbose mode. For <b>X22</b> : 0 = off (disabled) 1 = on (enabled) 2 = tagged responses for queries 3 = verbose mode and tagged responses for queries
<p><b>NOTE</b> The MGP can send out unsolicited information (such as notice of a volume or input change or a change in some other setting). That is called <i>verbose (wordy) relationship</i> between the processor and a connected device. For a direct RS-232/422 connection, the processor is set for Verbose mode by default. When the MGP 462 is connected via Ethernet, Verbose mode is disabled by default in order to reduce the amount of communication traffic on the network. If you want to use the Verbose mode with a processor connected via Ethernet, this mode must be set to On each time you reconnect to the processor.</p>				
Read Verbose mode	<b>Esc</b> CV ←	WCV	<b>X22</b> ↓	
Read connection's security level	<b>Esc</b> CK ←	WCK	<b>X52</b> ↓	For <b>X52</b> : 0 = anonymous 1–10 = extended security levels 1 through 10 11 = User 12 = Administrator
<p>With tagged response – verbose modes 2 and 3: Pv   <b>X52</b> ↓</p>				
<b>Remapping port designations</b>				
Set Telnet port map <sup>24</sup>	<b>Esc</b> {port#}MT ←	W{port#}MT	Pmt {port#} ↓	
Reset Telnet port map <sup>24</sup>	<b>Esc</b> 23MT ←	W23MT	Pmt 00023 ↓	
Disable Telnet port map <sup>24</sup>	<b>Esc</b> 0MT ←	W0MT	Pmt 00000 ↓	
Read Telnet port map	<b>Esc</b> MT ←	WMT	{port#} ↓	
Set Web port map <sup>24</sup>	<b>Esc</b> {port#}MH ←	W{port#}MH	Pmh {port#} ↓	
Reset Web port map <sup>24</sup>	<b>Esc</b> 80MH ←	W80MH	Pmh 00080 ↓	
Disable Web port map <sup>24</sup>	<b>Esc</b> 0MH ←	W0MH	Pmh 00000 ↓	
Read Web port map <sup>24</sup>	<b>Esc</b> MH ←	WMH	{port#} ↓	
Set Direct Access port map <sup>24</sup>	<b>Esc</b> {port#}MD ←	W{port#}MD	Pmd {port#} ↓	

## Command/response table for IP control port commands (continued)

Command	ASCII (Telnet) (host to processor)	URL Encoded (Web) (host to processor)	Response (processor to host)	Additional description
<b>Remapping port designations, continued</b>				
Reset Direct Access port map <sup>24</sup>	<code>[Esc] 2001MD ←</code>	W2001MD	Pmd 02001 ↓	
Disable Direct Access port map <sup>24</sup>	<code>[Esc] 0MD ←</code>	W0MD	Pmd 00000 ↓	
Read Direct Access port map <sup>24</sup>	<code>[Esc] MD ←</code>	WMD	{port#} ↓	
<b>Listing connections</b>				
Get connection listing	<code>[Esc] CC ←</code>	WCC	(See below.)	
<b>Unit Telnet text responses:</b> Remote client IP address: port number, time/date when connection was made, total connection time ↓ Remote client IP address: port number, time/date when connection was made, total connection time ↓ Remote client IP address: port number, time/date when connection was made, total connection time ↓ ... Total clients • connections available ↓ ↓ <b>Unit Web responses: HTML Sample Code</b> <pre> var connections = new Array (); connections [1] = 'Client IP1, timestamp 1, uptime 1'; connections [2] = 'Client IP2, timestamp 2, uptime 2'; connections [3] = 'Client IP3, timestamp 3, uptime 3'; ... connections [n] = 'Client IPn, timestamp n, uptime n'; connections [n + 1] = 'total clients, connections available';           </pre>				

## Command/response table for IP control port commands (continued)

Command	ASCII (Telnet) (host to processor)	URL Encoded (Web) (host to processor)	Response (processor to host)	Additional description
<b>File commands</b>				
Read Direct Access port map	<b>Esc</b> MD ←	WMD	{port#} ↵	Retrieve a list of files stored in the MCP 462. Each line of the response lists a file name and its corresponding file size. The last line of the response indicates how much available file space remains.
Get listing	<b>Esc</b> DF ←	WDF	(See below.)	
				<pre> Unit Telnet text responses: Unit Web responses: filename x • date/time * length ↵ filename x • date/time * length ↵ filename x • date/time * length ↵ filename x • date/time * length ↵ ... space_remaining • Bytes left ↵ ↵ file [n] = 'filename n, date n, filesize n'; file [n + 1] = 'space remaining, Bytes left' </pre>
<b>Stream files via port 80</b>				
Load file to user flash memory	Use POST on port 80 followed by the delimited data to be written to the flash file memory.			
Retrieve file from user flash memory	Send a page GET on port 80 followed by: WSF		[Responds with raw unprocessed data in file.]	
	<i>Example:</i> http://192.168.254.254/mypage.html?cmd=WSF			
<b>Stream files via Telnet or RS-232</b>				
Load file to user flash memory	<b>Esc</b> + UF filesize, filename ←		[Raw unprocessed data in file up to filesize]	
Retrieve file from user flash memory	<b>Esc</b> filename SF ←	1B filename 52 46 0D	Upl ↵	[Responds with raw unprocessed data in file + 1 byte checksum.]

## Command/response table for IP control port commands (continued)

Command	ASCII (Telnet) (host to processor)	URL Encoded (Web) (host to processor)	Response (processor to host)	Additional description
<b>Directory commands</b>				
Change/create directory	<b>Esc</b> {path}/{directory}/CJ ←	W {path}/{directory}/CJ	Dir•{path}/{directory}/ ↓	
<b>NOTE</b> A directory does not actually exist until a file has been copied into the path.				
Move back to root directory	<b>Esc</b> / CJ ←	W%2FCJ	Dir• / ↓	
Move up one directory	<b>Esc</b> ..CJ ←	W%2E%2ECJ	Dir•{path}/{directory}/ ↓	
View current directory	<b>Esc</b> CJ ←	WCJ	{path}/{directory}/ ↓	
<b>File erase commands</b>				
Erase user-supplied Web page/file <sup>24, 28</sup>	<b>Esc</b> {filename} EF ←	W {filename} EF	Del • {filename} ↓	
Erase current directory and its files <sup>24, 28</sup>	<b>Esc</b> / EF ←	W / EF	Ddl ↓	
Erase current directory and subdirectories <sup>24, 28</sup>	<b>Esc</b> // EF ←	W // EF	Ddl ↓	
<b>Reset (ZAP)/Erase commands</b>				
Erase flash memory <sup>24</sup>	<b>Esc</b> ZFFF ←	WZFFF	Zpf ↓	
Reset all device settings to factory default <sup>24</sup>	<b>Esc</b> ZXXX ←	WZXXX	Zpx ↓	No IP-related settings are reset.
Absolute system reset	<b>Esc</b> ZQQQ ←	WZQQQ	Zpq ↓	Reset all settings/memories. The ZQQQ command resets all settings, adjustments, the IP address, and subnet mask to the factory default values. The IP address is reset to 192.168.254.254, and the subnet mask is set to 255.255.0.0. (This command is identical to Reset mode 5).
Absolute reset retaining IP address	<b>Esc</b> ZY	WZY	Zpy ↓	All settings are reset except the IP address.

---

## Using the Windows®-based Control Software

The MGP 462 Windows-based control software program provides a convenient way to configure the inputs, output, windows, and images in each window. It also lets you save and recall input and window presets, and perform nearly all the other functions that can be accomplished via the front panel controls, the SIS commands, or the MGP 462 Web pages.

Using the software, you can do the following types of tasks to configure your MGP:

**Input configuration** — Specify a name; video signal type; size in pixels of the active video area; horizontal/vertical start points of the total video display area; and the windows 1 and 2 pixel sampling points (pixel phase) for each of the 6 inputs.

**Output configuration** — Set output resolution, refresh rate, sync polarity, and signal type (RGBHV, RGBS, RGsB, or YUV bi-level and tri-level); select a test pattern; and enable/disable blue mode in order to set video color and tint levels.

**Picture controls** — Position and size the four windows and the images within the windows, zoom in or out on the images/windows, and make fine adjustments to contrast, brightness, color, tint, and detail.

**Presets** — Create, save, and recall window and input presets.

**Window configuration** — Set window priority; border color; text label colors, size, and location; and transition effects for each window of the display.

**Background capture** — Capture the entire display on the output screen and save it as a bitmap, to be recalled and used as a window background when needed.

## Installing the software

The MGP 462 control software is provided on a CD that is delivered with your MGP 462 unit. To use the software that is on the CD, you must install the program on your computer. Follow these steps:

1. Insert the CD ROM into your CD drive. The disk should start automatically. If it does not, double-click LAUNCH.EXE on the CD to start it.
2. On the Software Installation screen (shown on the next page), click the MGP 462 Control Software link (outlined in red in the illustration).

# Software Configuration and Control, cont'd

The screenshot shows the Extron Electronics Software Installation page. The header includes the Extron logo and the title "Software Installation". The main content area is titled "MGP 462 & MGP 464 Multi-Graphic Processors". On the left, there is a sidebar with "Extron MGP 462 & MGP 464 Multi-Graphic Processors" and a list of manuals and control software for MGP 462, MGP 462D, MGP 464, and MGP 464DI. The main content area has three sections: "Install Programs" with instructions to install MGP 462 Control Software (Version 1.0), MGP 464 Control Software (Version 1.2), IP Link® File Manager Software (Version 1.1.3), and Extron Button Label Generator Software (Version 3.1.1); "User's Manuals" with a link to view the user's manual; and "Help" with links to the MGP 462 and MGP 464 Control Software Help Files. There is also a note to install Adobe Acrobat Reader to view PDF files.

## Link to the installation software on the MGP 462 CD

3. On the File Download window that appears, click Run to begin installing the program.

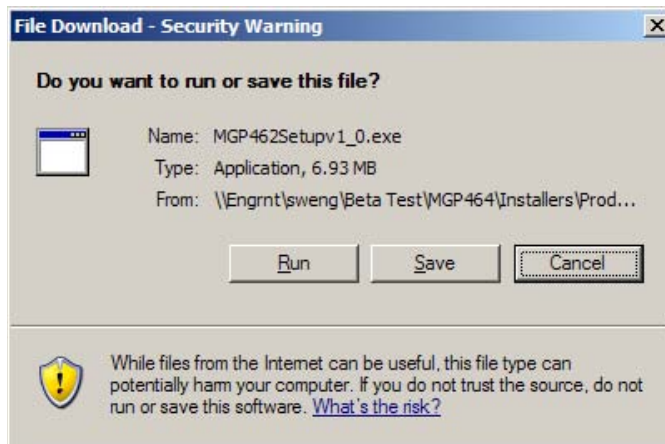

## File Download window

If you want to save the installation file (MGP462Setupv2\_n.exe) to your desktop, click Save. On the Save As window, save the setup file to the desired location on your PC. When you are ready to install the software, double-click on the MGP462setupv2\_n.exe icon.

4. A Security prompt appears. Click Run on this window to continue with the installation.
5. Follow the instructions on the InstallShield Wizard screens to complete the program installation.

By default the installation creates a folder called "MGP462" in the following location on the PC:

**c: \Program Files\Extron\MGP462**

If there is no Extron folder in your Program Files folder, the installation program creates it as well.



---

## Starting the control program

Most items in the MGP 462 configuration program can also be configured via the front panel, described in chapter 3. Refer to that chapter for details on features and settings. The MGP 462 software Help program provides information on settings and on how to use the configuration program itself.

1. To run the MGP 462 configuration program, do either of the following:
  - Double-click on the MGP462.exe icon, located on your computer at:  
**c: \Program Files\Extron\MGP462**
  - Access the program from the Start menu on your computer:
    - a. Click Start on your computer screen.
    - b. Select All Programs from the Start menu.
    - c. From the All Programs menu, select Extron Electronics.
    - d. From the Extron Electronics menu, select MGP 462.
    - e. Select MGP 462 Control Program. The Communication Type Selection window appears.
2. On the Communication Type Selection window, select the tab for the communication method you want to use between your computer and the MGP 462.
  - Select TCP/IP if you are using the LAN port.
  - Select RS232 if you are using the RS-232/422 serial port.

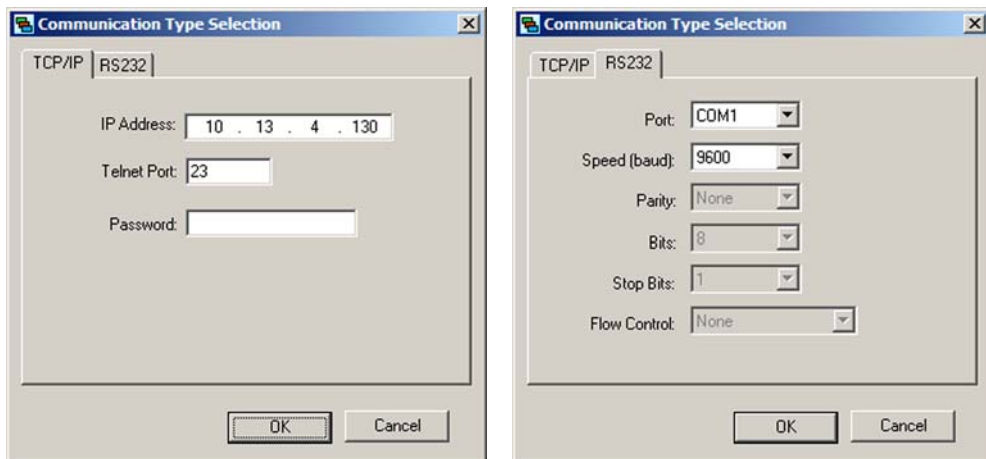

### **Comm Port Selection window with TCP/IP and RS232 tabs**

3. On the selected tab, enter the information required for the type of communication you chose.
  - **TCP/IP:** Enter your MGP's IP address, Telnet port (the default is 23), and a password if desired.
  - **RS-232/422:** Select your PC's communication port from the Port menu, and the baud rate from the Speed menu. All other parameters are preset.
4. Click OK. After a few seconds, the MGP 462 main window opens.

# Software Configuration and Control, cont'd

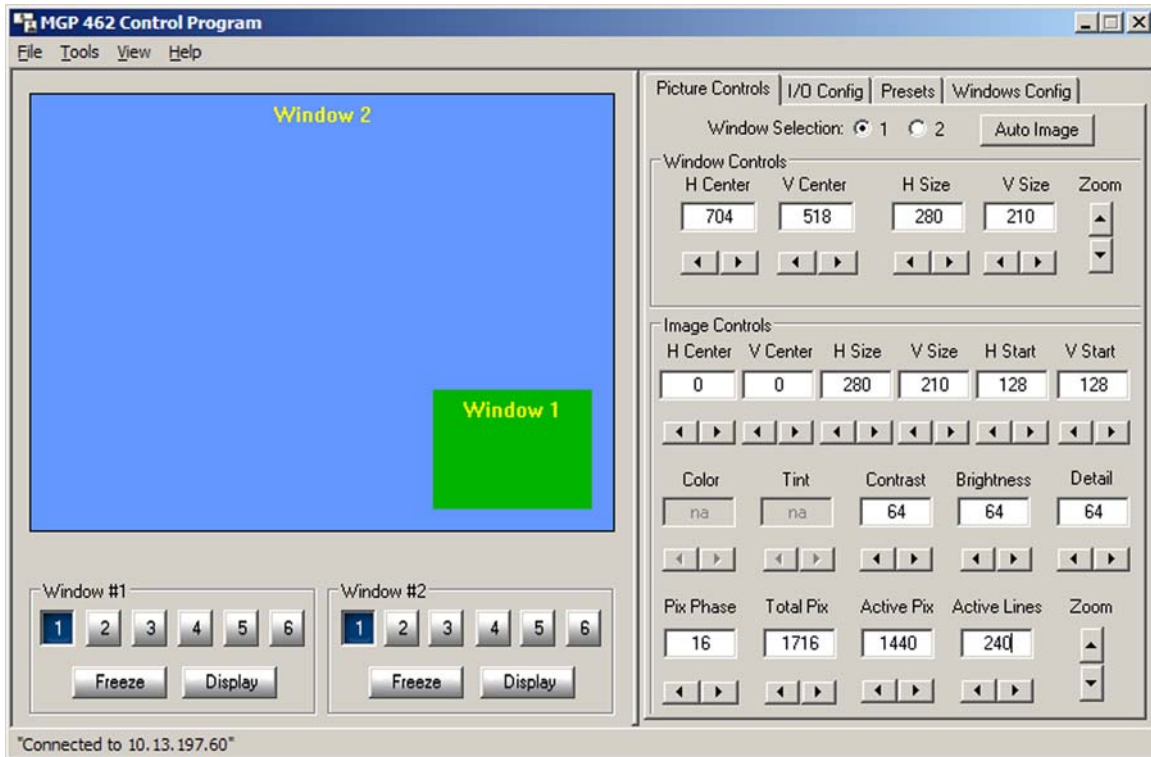

## MGP 462 window

5. For information on configuring the MGP 462 using the Windows-based software, refer to the program's Help. To access the Help file, select Contents from the Help pull-down menu, or press the F1 key.

## Using the Button Label Generator

The Button Label Generator software creates labels that you can place inside the translucent covers of the input and output push buttons. You can create labels with names, alphanumeric characters, icons, and even colored bitmaps for easy and intuitive input and output selection. See *Installing or Replacing Button Labels* in chapter 2 for procedures for removing and replacing the translucent covers.

The program is contained on the same CD-ROM as the MGP Windows-based control software, and is installed automatically when you install the control software.

By default, the Windows installation goes in the C:\ProgramFiles\Extron\ButtonLabelGenerator directory. The Button Label Generator icon is placed in the "Extron Electronics" group or folder.

1. To run the Button Label Generator program, double-click on the Button Label Generator icon (shown at right) in the Extron Electronics group or folder. The Button-Label Generator window appears (see the figure on the next page).
2. From the Systems pull-down menu, select a system button configuration.

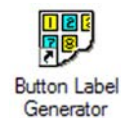

The MGP 462 selections most closely matches the button configuration of the MGP. However, you can select any option from this menu. You can also select Customize Button Layouts, which opens a blank worksheet on which you can place your own buttons in the desired configuration.

- Click on the button representation that you want to edit. A red box surrounds the selected button.



### **Button Label Generator window for the MGP 462**

- Edit the selected button by using any of the tools provided on the Button Label Generator window. Some of the edits you can make are:
  - Enter text in the text field on the button representation.
  - Select the font, size, and color of the text from the drop-down menus on the tool bar.
  - Select an icon from the Button Picture Palette and drag it to the desired button.
  - Place a bitmap image from your computer on a selected button.
  - To remove all the text or the image from a button label, click Clear Button. To remove the text and images from all the button labels, click Clear All Buttons.

To access the Button Label Generator Help program, select Use Help from the Help menu.

- When finished creating the labels, print them out by selecting Print from the File pull-down menu in the upper-left corner of the Button Label Generator Window.

To save the button label set as a .xml file on your computer, select Save As from the File menu and give the label file a name.

# Software Configuration and Control, cont'd

---



## MGP 462 Multi-Graphic Processor

# 5 Chapter Five

## **Ethernet Configuration and Control**

Accessing the Web Pages

Viewing System Status

Using the Configuration Pages

Using the File Management Page

Using the Control Pages

# Ethernet Configuration and Control

The MGP 462 can be controlled and configured using HTML Web pages accessed over a network or from a local PC connected to the MGP 462's LAN port. The MGP 462 has factory-installed HTML Web pages that allow you to select and configure inputs, adjust picture controls, configure windows, save and recall presets, and perform other processor functions. Access these HTML pages using a Web browser such as Microsoft's Internet Explorer.

**NOTE** *Administrators have access to all of the Web pages and are able to make changes to settings. Users can access the pages on the **System Status** and **Control** tabs only.*

## Accessing the Web Pages

To access the MGP 462's HTML Web pages:

1. Start your Web browser program.
2. Enter the MGP 462's IP address in the browser's Address field.

**NOTE** *If your local system administrators have not changed the value, use the factory-specified default, 192.168.254.254, in this field.*

3. If you want the browser to display a page other than the default page (such as a custom page that you have created and uploaded), enter a slash (/) and the name of the custom page file to open.

**NOTE** *The browser's Address field should display the address in the following format: xxx.xxx.xxx.xxx/{optional\_file\_name.html}*

**NOTE** *The following characters are **invalid** in file names: ? ~ @ = ' [ ] { } < > ' " ; : | \ and space.*

4. Press the Enter key. If the MGP 462's HTML pages are not password protected, the browser displays a start page as described in step 5.

If the MGP 462's HTML page is password protected, the browser displays the Enter Network Password page.



### Example of an Enter Network Password window

- a. Enter the administrator or user password in the Password field.

**NOTE** *A User Name entry is not required.*

- b. If desired, select the check box to have the system input your password the next time you enter your MGP 462's IP address.
- c. Click the OK button.

- If in step 4 you entered the filename for a custom HTML page, the browser displays that page. If not, the browser displays the System Status page, which is the MGP 462's default start page. You can select the tabs at the top of this screen to display additional screens that enable you to configure and control the MGP 462.

## Viewing System Status

The System Status Web page on the Status tab provides information on your MGP 462's current settings. Changes to these settings can be made via the Configuration Web pages, SIS programming, the Windows-based control software, or the MGP 462 front panel. Personnel who have user access can view this page but cannot access the Configuration pages; they see only the Status tab. The following figure shows a typical MGP 462 System Status web page.

The screenshot displays the Extron Electronics System Status web page. The page has a blue header with the Extron logo and navigation tabs for Status, Configuration, File Management, and Control. The user is logged in as Admin. The main content area is titled 'System Status' and includes a message: 'Below are your Unit's current system settings. To make changes, click on the 'Configuration' tab.' The settings are organized into three sections: System Description, IP Settings, and Serial Port Settings.

System Description			
Model:	MGP462		
Description:	Multi-Graphic Processor		
Part Number:	60-623-01	Firmware Version:	2.01
Date:	8/02/2006	Temperature:	116.60 F / 47.00 C
Time:	08:34 AM	# of Connections:	002

IP Settings	
Unit Name:	MGP462-00-0B-2C
DHCP:	Off
IP Address:	10.13.197.60
Gateway IP Address:	0.0.0.0
Subnet Mask:	255.255.0.0
MAC Address:	00-05-A6-00-0B-2C

Serial Port Settings	
Port:	1
Port Type:	RS-232
Baud Rate:	9600
Data Bits:	8
Parity:	None
Stop Bits:	1
Flow Control:	None

### System Status screen

On password-protected connections, there are two levels of protection: administrator and user. Administrators have full access to all the MGP's functions. Users can only view all the settings except passwords.

- Ethernet connection to the MGP, either entering SIS commands or using the Windows-based Control Program (see chapter 4, *Software Configuration and Control*) is password protected.
- Connection via the RS-232/RS-422 port is **not** password protected.

# Ethernet Configuration and Control, cont'd

## Using the Configuration Pages

There are five Configuration Web pages, which only administrators can access. They are listed in the sidebar menu at the left of the Configuration screen. The following sections describe the changes you can make from these screens.

### System Settings screen

The System Settings screen is divided into two sections, in which you can set date and time parameters, and change the IP information for the MGP 462. In each section, click Submit to enter your changes. Clicking the Cancel button in either section restores the previous settings, if the new values have not been submitted.

**Extron Electronics**

Status Configuration File Management Control

Logged on: Admin Log Off Contact Us

800.633.9876

System Settings  
Scaler Settings  
Passwords  
Email Alerts  
Firmware Upgrade

www.extron.com

### System Settings

Below are your Unit's basic System Settings. Most units will work with the default IP Settings without making any changes. If you require help changing your settings, please refer to the user guide.

#### IP Settings

Unit Name:	<input type="text" value="MGP462-00-0B-2C"/>	MAC Address:	00-05-A6-00-0B-2C
DHCP:	<input type="radio"/> On <input checked="" type="radio"/> Off	Firmware:	2.01
IP Address:	<input type="text" value="10.13.197.60"/>	Model:	MGP462
Gateway IP Address:	<input type="text" value="0.0.0.0"/>	Part Number:	60-623-01
Subnet Mask:	<input type="text" value="255.255.0.0"/>		

Submit Cancel

#### Date/Time Settings

Date:	<input type="text" value="8"/> <input type="text" value="2"/> <input type="text" value="2006"/>	<input type="button" value="Local Date/Time"/>
Time:	<input type="text" value="8"/> <input type="text" value="39"/> <input type="text" value="AM"/>	
Zone:	<input type="text" value="(GMT-08:00) Pacific Time (US &amp; Canada), Tijuana"/>	
Daylight Saving:	<input type="radio"/> Off <input checked="" type="radio"/> USA <input type="radio"/> Europe <input type="radio"/> Brazil	

Submit Cancel

**System Settings screen**

### IP Settings fields

The IP Settings fields provide a location for viewing and editing settings unique to the Ethernet interface. After editing all desired settings in the IP Settings section, click the Submit button at the bottom of this section.

#### Unit Name field

The Unit Name field contains the name used as the "from" information when the MGP e-mails notification of its failed or repaired status. You can change this name field to any valid name, up to 24 alphanumeric characters.

**NOTE** *The following characters are **invalid** in the unit name:*  
+ ~ , @ = ' [ ] { } < > ' " ; : | \ and ?.

#### DHCP radio buttons

The DHCP On radio button directs the MGP to ignore any entered IP addresses and to obtain its IP address from a Dynamic Host Configuration Protocol (DHCP) server (if the network is DHCP capable).

The DHCP Off radio button turns DHCP off. Contact your local system administrator to find out this control's setting.



---

### IP Address field

The IP Address field contains the IP address of the connected MGP. This value is encoded in the processor's flash memory.

Valid IP addresses consist of four 1-, 2-, or 3-digit numeric subfields separated by dots (periods). Each field can be numbered from 000 through 255. Leading zeros, up to 3 digits total per field, are optional. Values of 256 and above are invalid.

The factory-installed default address is 192.168.254.254, but if this conflicts with other equipment at your installation, you can change the IP address to any valid value.

**NOTE** *IP address changes can cause conflicts with other equipment. Only local system administrators should change IP addresses.*

### Gateway IP Address field

The Gateway IP Address field identifies the address of the gateway to the mail server to be used if the MGP and the mail server are not on the same subnet.

The gateway IP address has the same validity rules as the system IP address.

### Subnet Mask field

A subnet is a **subset** of a **network** — a set of IP devices that have portions of their IP addresses in common. The Subnet Mask field is used to determine whether the MGP is on the same subnet as the mail server when your unit is part of a subnet. The subnet mask can be obtained from your system administrator.

### MAC Address field

The Media Access Control (MAC) Address is hard coded in the MGP and cannot be changed.

## Setting the date and time

The Date/Time Settings fields provide a location for viewing and setting the date and time functions. Change the date and time settings as follows:

1. In the desired Date/Time Settings field, click the desired variable's drop box. The adjustable variables are month, day, year, hours, minutes, AM/PM, and (time) zone. A drop-down scroll box appears.
2. Click and drag the slider or click the scroll up button or scroll down button until the desired variable is visible.
3. Click on the desired variable.

**NOTE** *If setting the time, set the local time. The Zone variable allows you to then enter the offset from Greenwich Mean Time (GMT).*

**NOTE** *The Zone field identifies the standard time zone that has been selected and displays the amount of time, in hours and minutes, that the local time varies from the GMT international time reference.*

4. Repeat steps 1 through 3 for other variables that need to be changed.
5. Select the appropriate Daylight Saving radio button. To turn off daylight savings time, select Off.

**NOTE** *When daylight savings time is enabled, the MGP updates its internal clock between Standard Time and Daylight Savings Time in the spring and fall on the date that the time change occurs in the United States of America and parts of Europe and Brazil. When daylight savings time is turned off, the MGP does not adjust its time reference.*

6. Click the Submit button at the bottom of the Date/Time Settings section to implement your selections.

# Ethernet Configuration and Control, cont'd

## Scaler Settings screen

On the Scaler Settings screen, you can specify many configuration settings for the six inputs, the output, and windows 1 and 2. You can also make changes to the screen background, select a test pattern, enable and disable Blue mode, and select between RS-232 and RS-422 for the serial port mode.

**Extron Electronics**

Status Configuration File Management Control

800.633.9876

Logged on: Admin Log Off Contact Us

System Settings  
Scaler Settings  
Passwords  
Email Alerts  
Firmware Upgrade

www.extron.com

### Scaler Settings

**Input Configuration**

1	2	3	4	5	6
----Input1----	----Input2----	----Input3----	----Input4----	----Input5----	----Input6----
RGB	RGB	RGB	RGB	Composite	Composite

**Output Configuration**

Resolution: 1024x768 Refresh Rate: 60Hz Sync Format: RGBHV Polarity: H- V-

**Window Configuration**

**Window Priority**  
 Front 1 - Back 2  
 Front 2 - Back 1

**Window Effect**  
Cut

**Effect Duration**  
0.5 sec

**Windows 1 & 2**  
Text Location: None  
Text Size:  
 Small  
 Medium  
 Large

**Window 1**  
Text Border Color: Black  
Text Color: Black  
Text Background Color: White  
Window Border Color: Off

**Window 2**  
Text Border Color: Black  
Text Color: Black  
Text Background Color: White  
Window Border Color: Off

**Advanced Configuration**

Background Color: None  
Test Patterns: Off

**Blue Screen Mode**  
 Off  
 On

**Serial Port Mode**  
 RS232  
 RS422

**Background Capture**

Save Background Image: NA Recall Background Image: NA

Submit Cancel

*Scaler Settings screen*

---

## Input configuration

The Input Configuration section of the Scaler Settings screen lets you name and select the video signal type for each of the six available inputs.

### Naming inputs

You can assign names to the six inputs using the input name text boxes located beneath each input number. Initially, a default name is displayed in each box:

----- InputN -----

Select the text in the box and delete it, then enter a name of up to 16 characters for the input. The following characters are available:

**Symbols:** : / - \_ + "

**Numerals:** 0 through 9

**Letters:** Lowercase a through z, uppercase A through Z

**Spaces**

### Selecting the video signal type

Under each input name box is a menu from which you can select the video signal type for the input.

RGB, YUVp, and RGBcV are available on inputs 1 through 4 only. YUVi is available on inputs 1 through 5. S-video and composite video are available on all six inputs. SDI is available only on the MGP 462D and only on input 6.

## Output configuration

In the Output Configuration section of the Scaler Settings screen, you can select output parameters from four pull-down menus.

**Resolution** — Select the resolution at which the image will be displayed on the output screen.

**Refresh rate** — Select the rate in Hz at which the output screen will be refreshed.

**Output Sync Format** — Select the output signal type required by the display device. Available formats are RGBHV, RGB, YUV bi-level, and YUV tri-level.

**Output polarity** — Select the combination of horizontal and vertical synchronization signal polarities.

## Window configuration

The menus and radio buttons in this section enable you to specify various parameters for windows 1 and 2.

**Window Priority** — Select which window is displayed in front, overlapping or covering the other window.

**Window Effect** — Select a transition effect that will be used when windows are muted (closed) or unmuted (opened). Refer to *Available effects*, in the *Window Configuration menu* section of chapter 3 for a description of the available transition effects.

**Dissolve Speed** — Select the amount of time that the MGP 462 will take to complete a transition (displaying the transition effect on the output screen) when muting a window.

**Text Location** — Select the area on the screen in which a text label will be displayed on both windows. The default is None, which specifies that no text label will be displayed.

**Text Size** — Select one of three possible sizes for the text label on both windows.

## Ethernet Configuration and Control, cont'd

---

### Parameters with separate menus for Window 1 and Window 2

**Text Border Color** — Select a color for the border surrounding the text label in the window. The default is Black.

**Text Color** — Select a color for the text displayed in the window. The default is Black.

**Text Background Color** — Select a color for the text label background. The default is White.

- **Off** specifies that there is no special background for the text label; only the window background (specified from the Advanced Configuration menu; see the next section) is behind the text.
- **Translucent** specifies that the window background shows through the text background with a cloudy effect.

**Window Border Color** — Select a color for the border around the entire window display. The default is Off, which specifies that there is no window border.

### Advanced Configuration

This section contains menus and radio buttons that allow you to select additional system parameters.

**Background Color** — Select a color for the background of the output screen display on both windows.

**Test Patterns** — Select a test pattern to be displayed on the output.

**Blue Screen Mode** — Turn Blue mode off or on. Blue mode causes only the sync and blue video signals to be passed to the display, which aids in the setup of the display color and tint.

**Serial Port Mode** — Select RS-232 or RS-422 control.

### Background Capture

The pull-down menus let you save an image, or to recall an image that has been saved and use it as the background for the two windows.

**NOTE** *The MGP 462 supports 24-bit bitmap files only. Their file names must have the format **Bkgnn.bmp**. See Background Capture menu in chapter 3 for information on calculating the size of an image.*

**Save Background Image** — From this menu, select a number to assign to the image you want to save.

**Recall Background Image** — From this menu, select the number that was assigned to the image that you want to use for the background behind the windows.

## Passwords screen

The Passwords screen lets you assign an administrator and/or user password to control access to the MGP 462 Web pages.

**NOTE** *An administrator password must be in place before a user password can be assigned.*

**NOTE** *Passwords must contain 4 to 12 alphanumeric characters. Symbols and spaces are not allowed, and the passwords are case sensitive.*

**Extron Electronics**

Status Configuration File Management Control

Logged on: Admin Log Off 800.633.9 Contact

**Passwords**

To update the Administration Password, enter the desired password, repeat the entry, and press 'Submit'. To update the User Password, enter the desired password, repeat the entry, and press 'Submit'. To clear a password, enter a single space, repeat the entry, and press 'Submit'. Minimum password length is 4 characters. Maximum password length is 12 characters. Passwords are case sensitive and special characters are not allowed.

**Passwords**

Administrator Password:  Re-enter Admin Password:

User Password:  Re-enter User Password:

Submit Cancel

### Passwords screen

#### Assigning a password

To assign passwords, follow these steps:

1. Enter the new administrator password in the Administrator Password field.
2. In the Re-enter Admin Password field, enter the same password again to confirm it.
3. If you want to assign a user password, enter it in the User Password field.

**NOTE** *You cannot assign a user password unless an administrator password has been assigned.*

4. Enter the same user password in the Re-enter the User Password field.
5. Click the Submit button to set the password(s).

#### Clearing a password

To remove an assigned password, follow these steps:

1. In the Administrator Password or User Password field, clear any text, then enter a single space.
2. Repeat step 1 in the Re-enter Admin Password or the Re-enter User Password field.
3. Click the Submit button.

# Ethernet Configuration and Control, cont'd

## Email Alerts screen

The Email Alerts screen enables you to set up the MGP 462 to automatically send e-mail alert messages when settings are changed on the unit. You may enter up to 64 e-mail addresses to alert recipients that an event has occurred.

You can also specify that SMTP (Simple Mail Transfer Protocol) authorization is required for the MGP to accept incoming e-mail. This prevents unwanted e-mail from taking up space in the MGP's mail system.

**Extron Electronics**

Status Configuration File Management Control

800.633.9876

Logged on: Admin Log Off Contact Us

**Email Alerts**

The settings below will allow you to configure your unit to send email alerts. Click 'Edit' and enter the email address to send a message to, and the file name that contains the message. File names must be alpha-numeric and are limited to 7 characters including the .eml file extension. Click 'Save' to save the change.

**Email Settings**

Mail IP Address: 0.0.0.0 Edit

Domain Name: [ ]

SMTP Authentication Required

User Name: [ ]

Password: [ ]

	Email Address	File Name	
1.	[ ]	[ ]	Edit
2.	[ ]	[ ]	Edit
3.	[ ]	[ ]	Edit
4.	[ ]	[ ]	Edit
5.	[ ]	[ ]	Edit
6.	[ ]	[ ]	Edit
7.	[ ]	[ ]	Edit
8.	[ ]	[ ]	Edit

### Email Alerts screen (top portion)

To set up the system to send e-mail alerts when settings are changed, follow these steps:

1. On the sidebar menu on the Configuration tab, click Email Alerts.
2. On the Email Alerts screen, click the Edit button located to the right of the Mail IP Address and Domain Name fields. The button changes to Save.
3. Enter your MGP 462's IP address and your domain name in the appropriate fields. (This information is available from your network administrator.)
4. Click the Save button.

To set up e-mail addresses for notification, do the following for each recipient of e-mail alerts:

1. Click the Edit button at the end of the address row. The Edit button changes to Save.
2. Enter the e-mail address of the recipient, and the file name on your computer (.eml extension) that contains the message.
3. Click the Save button to save the changes. The Save button changes back to Edit.

## Setting up SMTP authorization

To set the MGP to require SMTP authorization before accepting any e-mail, follow these steps:

1. To enable the SMTP authorization fields, click the Edit button at the right of the Mail IP Address field. The Edit button changes to Save.
2. Select the SMTP Authorization Required check box, located below the Domain Name field. This enables the User Name and Password fields below the check box.
3. In the User Name and Password fields, enter a user name and a password that senders must enter in order for the MGP to accept their e-mail messages.

For the User name, you can use any combination of letters, numerals, spaces, and symbols **except** the comma (,) and the single and double quotation marks (' and "). For the password, you can use all characters except the comma. The user name and password can each be from 1 to 30 characters.

**NOTE** You must specify **both** a user name and a password.

4. Click the Save button next to the Mail IP Address field to save your user name and password.

To remove SMTP authorization, click Edit, deselect the SMTP Authorization Required check box, then click Save.

## Firmware Upgrade screen

The Firmware Upgrade screen enables you to install a new version of firmware to your MGP 462. You can download the latest firmware version from the Extron Web site to your PC. Appendix C provides more details on firmware updating.

## Determining the current firmware version

There are four methods you can use to find out what firmware version is currently installed on your MGP 462:

- **Using the LCD screen:** Watch the LCD window as you connect the MGP 462 to a power source. The first piece of information displayed on the screen is the firmware version (along with the product name).
- **Using the System Status Web page:** Select the Status tab on the MGP Web page to display the System Status screen. The firmware version is the fourth line in the System Description section (shown below).

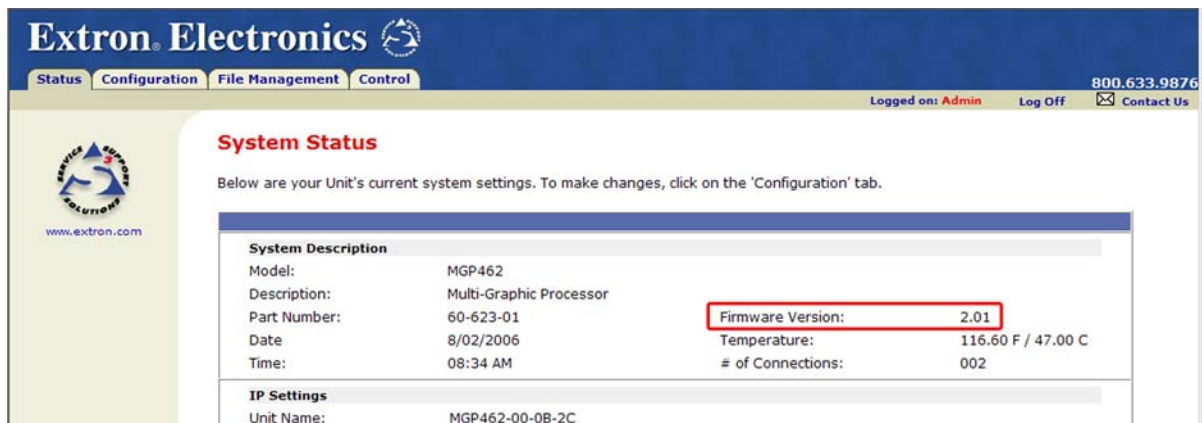

The screenshot displays the Extron Electronics System Status web page. The page has a blue header with the Extron logo and navigation tabs for Status, Configuration, File Management, and Control. The main content area is titled 'System Status' and includes a sub-header 'System Description' with a table of system parameters. The 'Firmware Version' field is highlighted with a red box, showing the value '2.01'. Below the System Description is the 'IP Settings' section, which shows the 'Unit Name' as 'MGP462-00-0B-2C'.

System Description	
Model:	MGP462
Description:	Multi-Graphic Processor
Part Number:	60-623-01
Date:	8/02/2006
Time:	08:34 AM
Firmware Version:	2.01
Temperature:	116.60 F / 47.00 C
# of Connections:	002

IP Settings	
Unit Name:	MGP462-00-0B-2C

**System Status screen showing firmware version**



## Ethernet Configuration and Control, cont'd

---

- Select About... from the Help menu on the Windows-based control software screen. See *Using the Windows-based Control Software* in chapter 4 for more information.
- Enter the appropriate SIS command. See *Using Simple Instruction Set (SIS) Commands* in chapter for for the command syntax.

### Downloading the firmware

To obtain the latest version of MGP 462 firmware, follow these steps:

1. Visit the Extron Web site ([www.extron.com](http://www.extron.com)) and go to the MGP 462 page.
2. Click Downloads.
3. On the Downloads page, click the Firmware link, listed under Software and Firmware.
4. On the Download Center page, fill in the required information, then click the Download\_MGP462\_FW2x01.exe button. A File Download – Security Warning window is displayed.
5. Click Save. A Save As window opens.
6. Browse to the folder where you want to save your firmware file, and click Save. The firmware installation file is placed on your computer drive.
7. When ready to install the new firmware, locate the downloaded file (called MGP462\_FW2x01.exe), and double-click on it to open it.
8. Follow the instructions on the screens to install the new firmware on your computer. A Release Notes file, giving information on what has changed in the new firmware version, and a set of instructions for updating the firmware are also loaded to your computer.

### Updating the firmware on the MGP 462

After you have installed the new firmware on your computer, you must upload it to the MGP 462. Follow these steps to update the firmware using the Web pages.

1. On the MGP 462's Configuration Web page, select Firmware Upgrade from the sidebar menu to display the Firmware Upgrade screen.
2. Click Browse to open the Choose File window, and locate the firmware file on your PC or server. The file extension must be **.S19**.



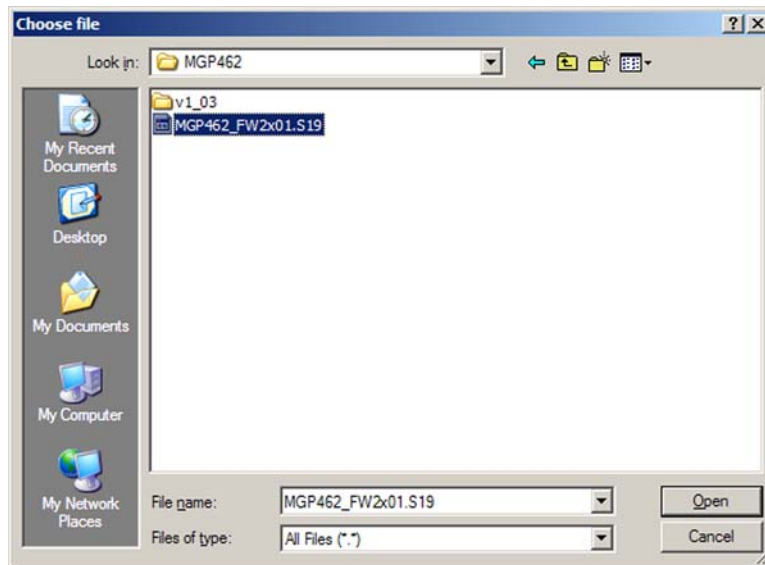

### **Choose file window**

**CAUTION** *Uploading a file with an extension other than .S19 may cause the unit to stop functioning.*

3. Open the firmware file. Its name appears in the field below the Current Firmware Version on the Firmware Upgrade screen.

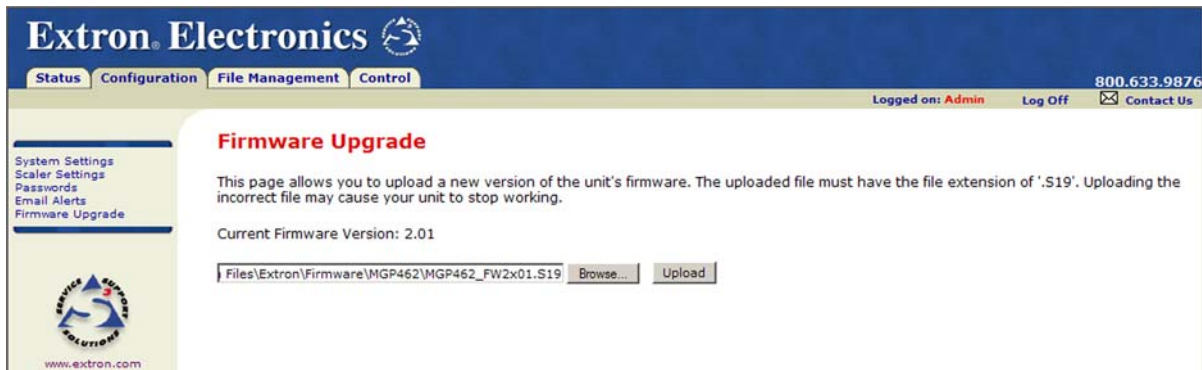

### **Firmware Upgrade screen**

4. Click the Upload button on the Firmware Update screen to start the firmware update process. While the firmware is being uploaded, the Upload button changes to Uploading...; and the LCD window on the MGP displays first **Firmware Upload Please Wait!!!**, then **Firmware Reboot Please Wait!!!**

**NOTE** *While the firmware is uploading and rebooting, do not press any front panel buttons or make any selections on the Web pages.*

When the uploading process is complete, the Uploading... button on the screen changes back to Upload, and the default cycle is displayed on the LCD screen.

# Ethernet Configuration and Control, cont'd

## Using the File Management Page

The File Management page lets you upload files to the MGP 462 from your PC or network, and to delete files from the unit. You can also upload personalized Web pages via this screen. To access the File Management page, select the File Management tab on the MGP 462 Web site.

You can use this function to load background images from your computer or the internet to display on the output screen. All background image files must be 24-bit bitmaps. Their file names must have the format **bkgm.bmp**.

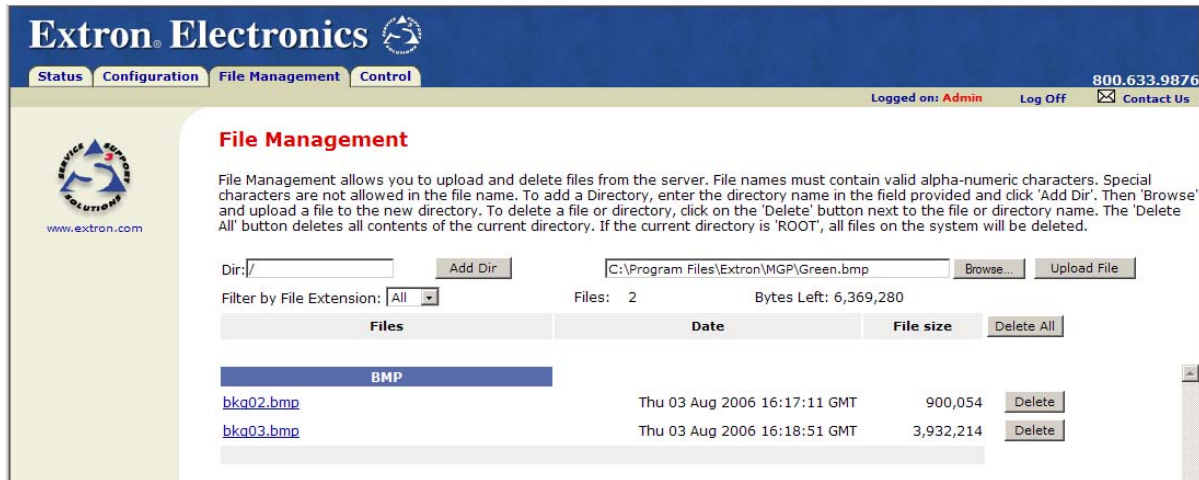

**File Management screen**

## Uploading files

Files to be uploaded to the MGP 462 must contain only valid alphanumeric characters and underscores. No spaces or special characters (symbols) are allowed.

To upload files from the server, follow these steps:

1. Click the Browse button to the right of the file name field.
2. Browse to locate the file that you want to upload, and open it. The file's name and directory path are displayed in the file name field on the File Management screen.
3. Click the Upload File button. The selected file name appears in the Files column on the File Management screen. (Files are listed separately under headings of their extensions.)

## Adding a directory

To add a directory or folder to the MGP 462's file system, follow these steps:

1. Enter the directory name in the Dir: field, following the slash (/).
2. Click the Add Dir button.
3. With the directory name displayed, perform the Uploading files procedure described in the previous section to add a file to the directory. The directory name appears at the top of the Files column, preceded by a slash.

To add more files to the directory, click the directory name to open it, then use the Uploading files procedure. To exit the directory, click (root).

## Other file management activities

You can also perform the following tasks on the File Management screen:

**Opening a file** — Click on the name of the file in the Files column.

**Deleting a file** — Click the Delete button at the right end of the line that contains the file you want to remove.

**Deleting all files** — Click the Delete All button.

**Selecting a file** — From the Select menu, select a file name, or select All to select all uploaded files.

## Using the Control Pages

The pages that you can access through the Control tab enable you to set and manage window and input presets, and to control other window-related functions.

### User Control screen

The User Control screen allows you to manage MGP 462 functions relating to the windows.

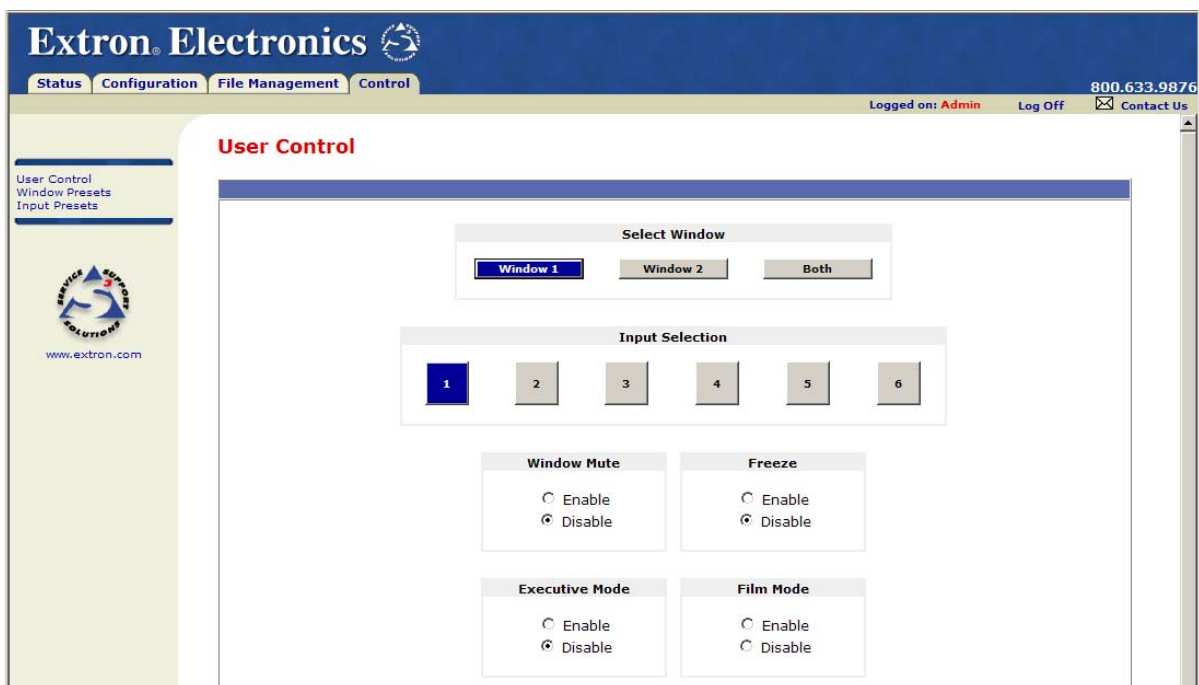

**User Control screen, top section**

### Select Window

Use the Window 1, Window 2, and Both buttons to specify the window(s) to which the following selections on this screen will apply. The Both selection can be used only when you are selecting inputs, muting the windows, or freezing/unfreezing the windows' video.

### Input Selection

Click one of the six Input Selection buttons to switch to that input for the selected window. The corresponding input button lights on the MGP 462 front panel.

# Ethernet Configuration and Control, cont'd

## Window Mute

Select the Enable or Disable radio button in the Window Mute field to mute/unmute the selected window. The corresponding Input button(s) on the front panel blink continuously when the window is muted.

## Executive Mode

Select the Enable radio button in the Executive Mode field to lock all front panel controls except Input Selection, Freeze, and Window Preset. (The RS-232/422 and Ethernet ports remain accessible.)

## Freeze

Select the Enable radio button in the Freeze field to freeze the image in the selected window. The front panel Freeze button(s) for the selected window(s) light when Freeze is enabled.

## Film Mode

Select the Enable radio button in the Film Mode field to have the MGP 462 detect whether 3:2 or 2:2 pull-down is needed to deinterlace the input video. The input you selected at the top of the screen must be set to YUVi, Composite, or S-video. (See *Using the Configuration Pages, Scaler Settings screen* section for information on selecting video signal types.)

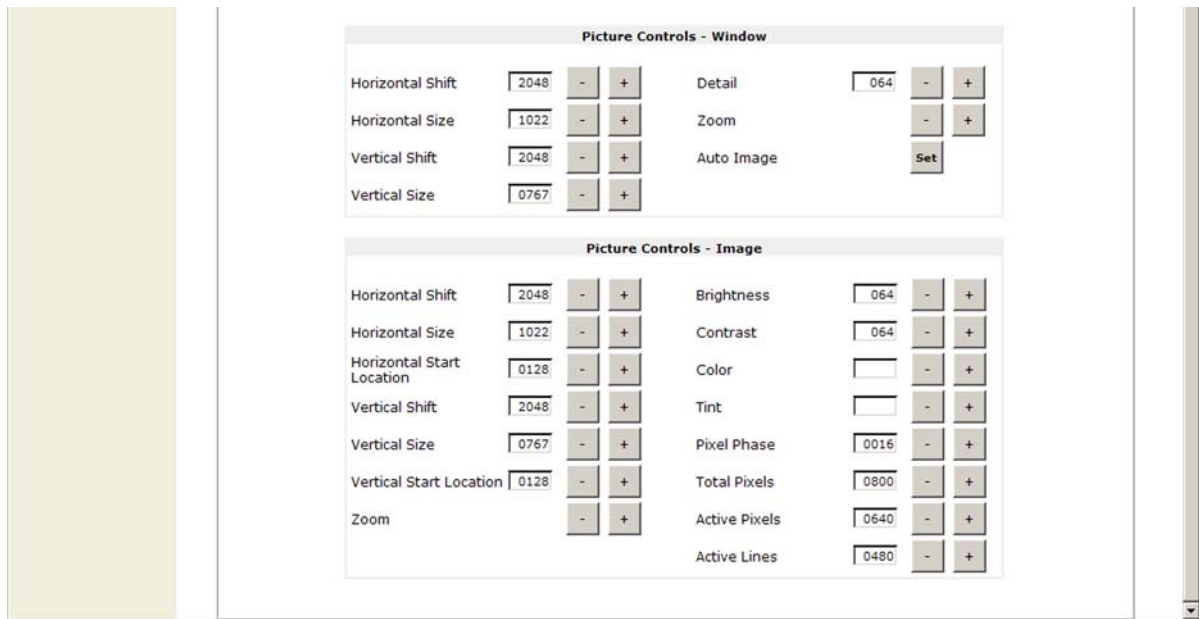

**User Control screen, bottom half**

## Picture Controls – Window

The Picture Controls section contains + and – buttons, which you can click to increase or decrease parameter values for the selected window. If a text field is provided, you can also enter the value in it.

You can make the following adjustments:

**Horizontal Shift** — Move the selected window to the right or left on the screen.

The value in the text box is the distance in pixels of the window's left edge from the left edge of the display. The range is determined by the output size; the default is 2048 plus or minus the output rate.

---

**Horizontal Size** — Stretch or shrink the selected window horizontally. The range is determined by the output rate.

**Vertical Shift** — Move the selected window up or down on the screen. The value in the text box is the distance in lines of the window's top edge from the top edge of the display. The range is determined by the output rate; the default is 2048 plus or minus the output rate.

**Vertical Size** — Stretch or shrink the selected window vertically. The value in the text box is the window's height in lines. The range depends on the output rate.

**Detail** — Adjust the sharpness of the image in the selected window. The range is 000 to 127; the default is 064.

**Zoom** — Increase the size of the image while keeping the aspect ratio constant. The zoom value is the same as the window size.

**Auto Image** — Perform an automatic image adjustment to the selected window. Auto Image measures where the active area starts and stops, and adjusts input sampling accordingly.

### Picture Controls – Image

This section contains + and – buttons, which you can click to increase or decrease parameter values for the image within the window that you selected at the top of the User Control screen. If a field is provided, you can also enter the value in it.

You can make the following adjustments:

**Horizontal Shift** — Move the image to the right or left in the selected window. The value in the text box is the distance in pixels of the image's left edge from the left edge of the window. The range is dependent on the output rate; the default is 2048 plus or minus the output rate.

**Horizontal Size** — Stretch or shrink the image horizontally. The value in the text box is the image's width in pixels. The range is dependent on the output rate.

**Horizontal Start Location** — Specify the distance in pixels from the left edge of the selected input's total video display area to the left edge of its active area. The default is 128.

**Vertical Shift** — Move the selected image up or down in the selected window. The value in the text box is the distance in lines of the image's top edge from the top edge of the window. The range is dependent on the output; the default is 2048 plus or minus the output rate.

**Vertical Size** — Stretch or shrink the selected image vertically. The value in the text box is the image's height in lines. The range is dependent on the output rate.

**Vertical Start Location** — Specify the distance in lines from the top edge of the selected input's total video display area to the top edge of its active area. The default is 128.

**Zoom** — Increase or decrease the size of the image in the selected window while keeping the aspect ratio constant. The range is dependent on the output rate.

**Brightness** — Increase or decrease the intensity of video light in the selected window. The range is 000 to 127; the default is 064.

# Ethernet Configuration and Control, cont'd

**Contrast** — Increase or decrease the range of image light and dark values in the selected window. The range is 000 to 127; the default is 064.

**Color** — Adjust the intensity of the colors in the selected window. (At the lowest adjustment, all colors appear as shades of gray.) The range is 000 to 127; the default is 064.

**Tint** — Change the appearance of the colors in the selected window. The range is 000 to 127; the default is 064.

**Pixel Phase** — Adjust the point at which pixels are sampled for the image in the selected window. The range is 1 to 31; the default is 16.

**Total Pixels** — Increase or decrease the width in pixels of the total line of video. The default is the auto-sensed value. The range is  $\pm 128$  from the auto-sensed value.

**Active Pixels** — Increase or decrease the width in pixels of the active video area of the selected input. The default is the auto-sensed value. The range is  $\pm 128$  from the auto-sensed value.

**Active Lines** — Increase or decrease the height in lines of the active video area of the selected input. The default is the auto-sensed value. The range is  $\pm 128$  from the auto-sensed value.

## Window Presets screen

The Window Presets screen lets you name, save, and recall up to 25 window presets that contain information for both windows. To create a preset, you save your MGP 462's current settings for the following:

Window border color	Text color
Window priority	Text border color
Window transition effect	Text background color
Transition effect duration	Text size
Background setting	Window size and position
Text location	Image size and position

The screenshot shows the 'Window Presets' screen in the Extron Electronics control interface. The page title is 'Window Presets' and it includes a descriptive paragraph: 'This screen allows you to name, save and recall Presets. Click the desired preset button, the Preset Name box will display the selected Preset Name, allowing you to change the name. Click 'Change Preset Name' to save the new name. Click 'Save Preset' to save the current window settings. Click 'Recall Preset' to recall the window settings of the selected preset.' Below this text is a form with a 'Window Preset Name:' input field and a 'Change Preset Name' button. Underneath are four buttons: 'Save Preset', 'Recall Preset', 'Recall Preset with Input', and 'Cancel'. The main area contains a grid of 25 buttons, each labeled 'WindowPreset--01' through 'WindowPreset--25'.

**Window Presets screen**



---

You can perform the following management activities on a window preset after you select the preset name from this screen.

### **Naming a window preset**

To change the name of a preset, follow these steps:

1. Select a preset by clicking its button. The name of your selected preset is displayed in the Window Preset Name field.
2. In the Window Preset Name field, enter the name you want to give the selected preset. The following characters are available:

**Symbols:** : / - + "

**Numerals:** 0 through 9

**Letters:** Lowercase a through z, uppercase A through Z

**Spaces**

3. Click the Change Preset Name button. The new name appears on the preset button you had selected.

### **Saving (creating) a window preset**

To save all the current window settings as a preset, do the following:

1. Click the button for the preset number to which you want to save the current settings.
2. Click Save Preset.

### **Recalling a window preset**

To recall a saved preset and enable all its settings, do the following:

1. Click the button for the preset number that you want to recall.
2. Click the Recall Preset with Input button to recall all window settings contained in the selected preset, including the input displayed when the preset was saved.

If you do not want to recall the inputs for the selected preset, click the Recall Preset button.

## **Input Presets screen**

The Input Presets screen lets you save and recall up to 128 input presets that each contain input configuration settings. To create an input preset, you save that input's current settings for the following:

Input signal type	Tint	Vertical start
Input name	Color	Pixel phase
Film mode Off/On	Detail (sharpness)	Active pixels
Brightness	Horizontal start	Active lines
Contrast	Image size (as a percent of the window)	

# Ethernet Configuration and Control, cont'd

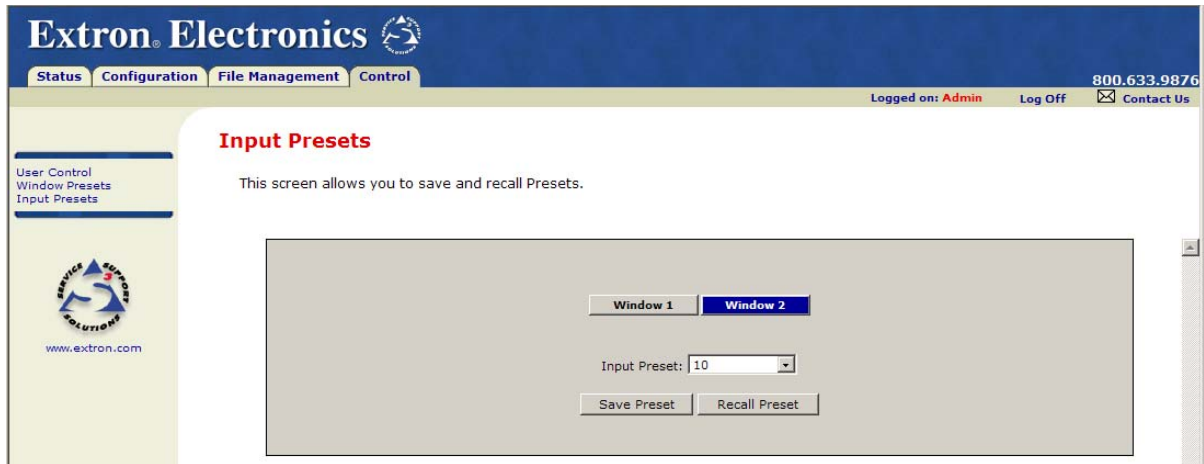

## **Input Presets screen**

You can perform the following management activities on an input preset after you select its number from this screen.

### **Saving (creating) an input preset**

To save all the settings for the currently selected input as a preset:

1. Click the Window 1 or the Window 2 button to specify the group of settings you want to save for the selected input.
2. From the Input Preset menu, select a preset number to which you want to save the selected input's settings.
3. Click Save Preset.

### **Recalling an input preset**

To recall a saved preset and enable all its settings on your MGP 462, follow these steps:

1. Click Window 1 or Window 2 to specify to which input the settings will be recalled.
2. From the Input Preset menu, select the preset number that you want to recall.
3. Click the Recall Preset button to enable all settings contained in the selected preset.





## MGP 462 Multi-Graphic Processor

# 6 Chapter Six

## Special Application

Connecting the MGP 462 to a Matrix Switcher

# Special Application

This chapter describes a special type of application that represents unique conditions. For the MGP 462 to operate properly in this situation, it is important to configure it correctly. The following pages describe an example of an application involving connection to a matrix switcher, along with its requirements for the MGP 462.

## Connecting the MGP 462 to a Matrix Switcher

When the MGP 462 is attached to a matrix switcher, such as the CrossPoint 450 shown below, inputs 1 and 2 come to the MGP through the switcher, which supports RGB, component video, S-video, and composite video signal types.

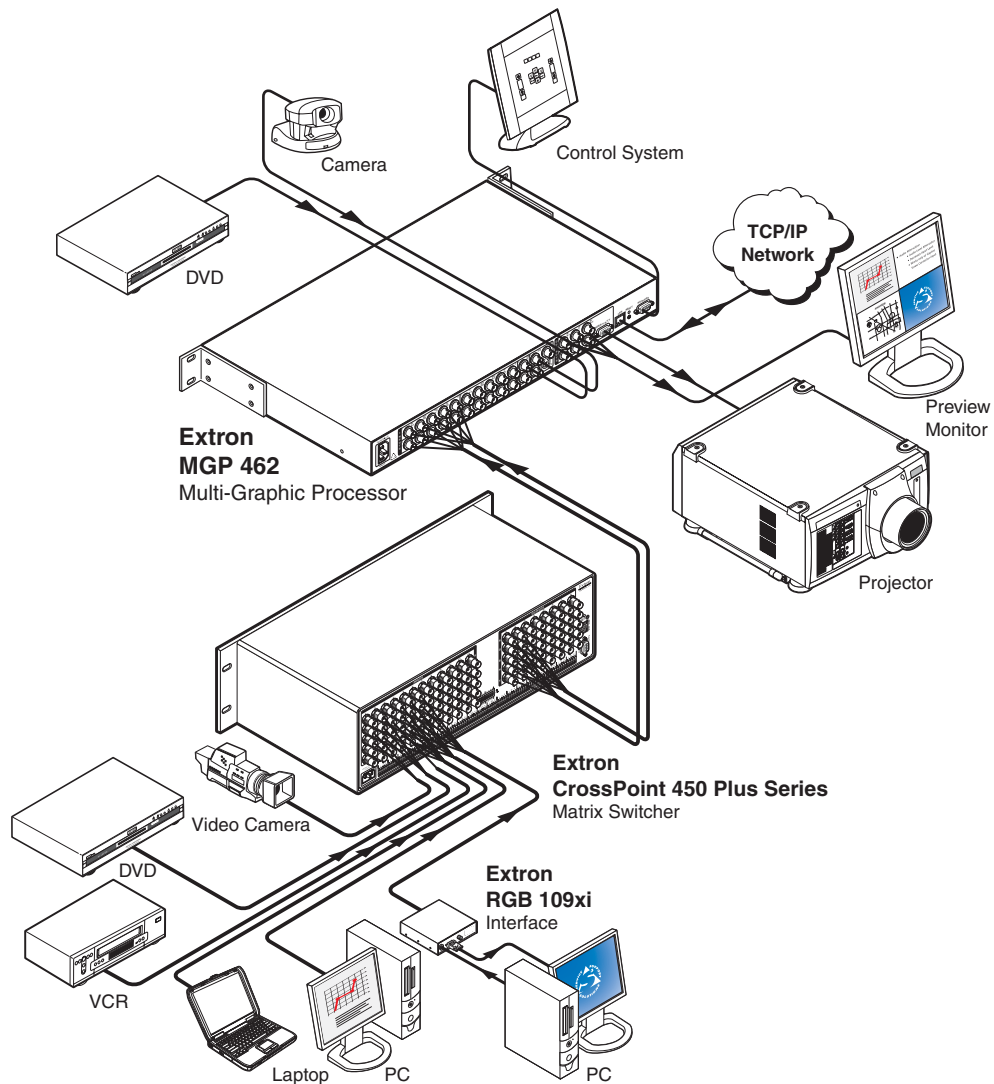

### ***MGP 462 connected to a matrix switcher***

In this type of configuration, the following occurs:

- On the MGP, window 1 displays input 1, and window 2 displays input 2.
- Input switches are made at the matrix switcher instead of at the MGP.

- Input presets are recalled on the MGP to correctly set up the input coming from the switcher. This setup can include the video signal type; picture controls; advanced input configuration functions such as setting the active lines/pixels, total lines/pixels, and pixel phase; and the input name.

You can perform the required MGP setup operations using any of the following:

- SIS commands (See chapter 4, *Software Configuration and Control*.)
- The MGP 462 Web pages (See chapter 5, *Ethernet Configuration and Control*.)
- The Windows-based control software (See chapter 4, *Software Configuration and Control*, and the software's Help.)

## Setting up the MGP to work with the switcher

Follow these steps to set up the MGP to work with a matrix switcher.

1. Install and connect the MGP as described in the *Connecting the MGP 462* section of chapter 2, with the exception of step **3**. In place of this step, do the following:

Connect two of the MGP's fully-configurable inputs to two of the matrix switcher's outputs. (See the diagram below.)

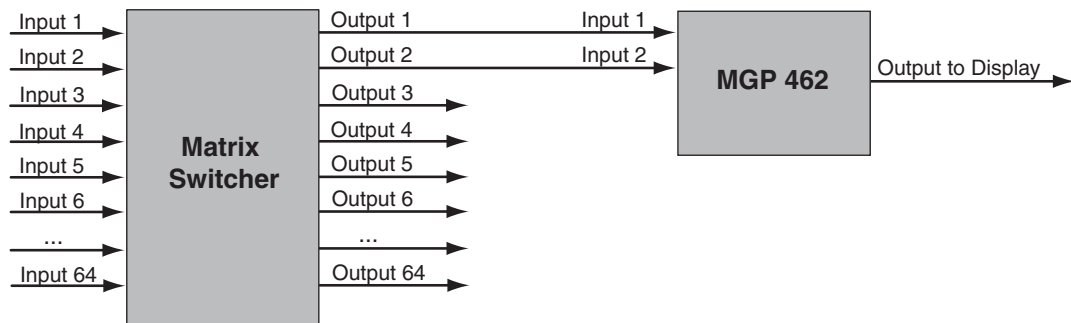

### Connecting the matrix switcher to the MGP 462

2. Size the windows on the MGP to full screen.
3. On the matrix switcher, tie input 1 to the two outputs connected to the MGP 462. Refer to your matrix switcher user's manual for the procedure.
4. Select window 1 on the MGP, and configure the input as follows:
  - a. Set the following input sampling parameters as desired: signal type, horizontal and vertical start, total pixels, active pixels, and active lines.
  - b. Set the following picture controls as desired: image size, image position, color, tint, brightness, and contrast.
  - c. Set the pixel phase for window 1, then mute the window to display the next window behind it. Repeat this step for window 2.
  - d. Save the adjusted settings as Input Preset 1.
5. Repeat step 4 for all inputs on the matrix switcher that will be displayed on the output screen via the MGP.

**NOTE** For convenience, you should save each input preset with the same number as the input on the matrix switcher.

## Special Application, cont'd

### Synchronizing the MGP 462 to the matrix switcher

The Windows-based control software contains a tool that synchronizes the MGP to a connected matrix switcher. The synchronization tool does the following:

- Provides the ability to automatically recall input presets when a switch is made on a connected switcher that has IP Link capability.
- Recalls all input preset settings so that the new input parameters (input type, size, centering, etc.) are the same as those with which the input was previously saved.
- Eliminates the need for a third party control system to manage input presets when the MGP is connected to a matrix switcher.

To use the synchronization tool, follow these steps:

1. Start the MGP 462 Windows-based control software. (See *Using the Windows-based control software* in chapter 4 for information on starting this program.)
2. From the Tools menu on the MGP 462 window, select Sync MGP 462 to Matrix Switcher.

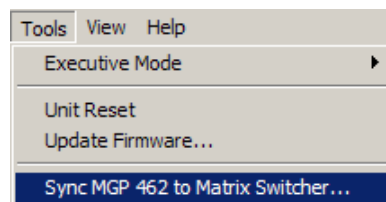

#### **Tools menu with Sync MGP 462 to Matrix Switcher selected**

The Sync MGP 462 to Matrix Switcher window opens.

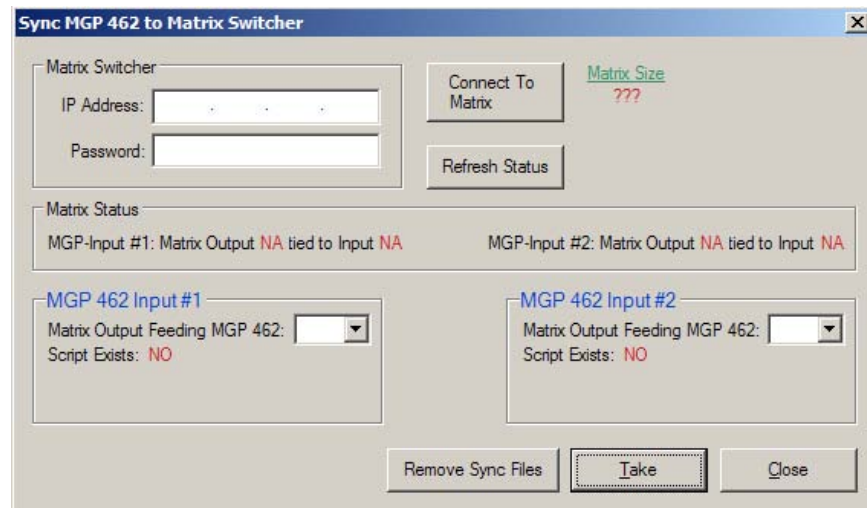

#### **Sync MGP 462 to Matrix Switcher window**

3. In the IP Address field, enter the IP address of your matrix switcher and its password (if required).

- Click the Connect To Matrix button located to the right of the IP Address field. When the connection is made, the size of the matrix switcher is displayed to the right of the Connect To Matrix button.

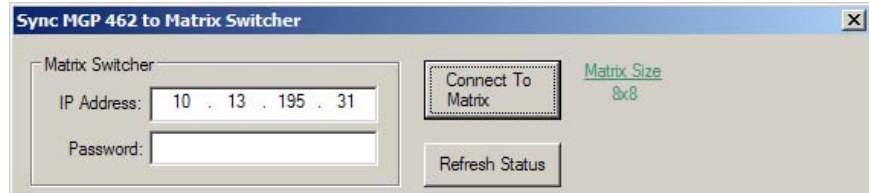

**Sync MGP to Matrix Switcher window showing matrix size**

- Important:** On your MGP, make sure that **input 1** is displayed in **window 1**, and that **input 2** is displayed in **window 2**. (See *Input Selection* in chapter 3 to select an input for a window.)
- From the MGP 462 Input #1 drop-down menu, select the number of the matrix switcher output that is connected to the MGP input 1.

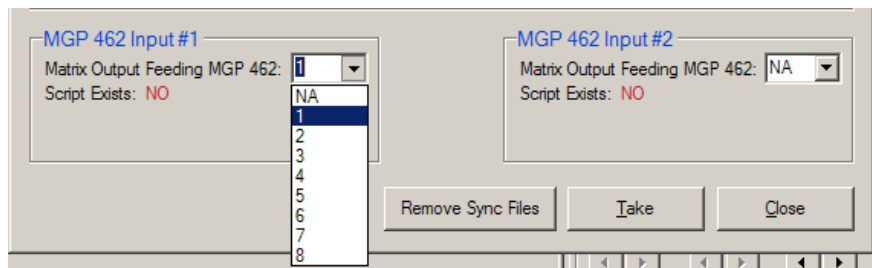

**Switcher output selection menu for MGP input 1**

- In the MGP 462 Input #2 menu, select the matrix switcher output that is connected to the MGP input 2.
- Click Take. Two event scripts are created on the MGP that continually monitor the input/output ties on the matrix switcher for the two outputs defined in steps 6 and 7.
  - The event scripts are programs that cause the MGP to continue monitoring the matrix switcher, whether or not the control software or the Sync tool is open.
  - If a new tie is made to the defined outputs, the preset for the new input is recalled.

**NOTE** *To mask any glitches on the video output, set the RGB delay on the matrix switcher to 1.0 seconds or greater. Refer to the user's manual for your switcher for the procedure.*

**To stop monitoring** the ties on the switcher, click the Remove Sync Files button on the Sync window. The event script files are removed from the MGP and sync monitoring stops. (This does not cause input presets to be lost.)

### **Additional setup procedures if using a third party control system without the MGP Sync tool**

When operating the system using a third-party control system, you can prevent the image from blanking or scrambling on the display during input switches by performing the following additional setup procedures:

1. While setting up the switcher and the MGP to work together, set the RGB delay on the matrix switcher to greater than, or equal to, 1.0 second.
2. Create a tie on the matrix switcher from desired input X to the output number that corresponds to MGP window Y, in which input X will be displayed.
3. Immediately (within 1 second) recall the input preset with the same number as switcher input X that you selected in step 2 (preset X), to MGP window Y.

**NOTE**

*Input presets cannot be recalled via the MGP front panel. You can recall them via SIS commands (see chapter 4), the MGP 462 Web pages (see chapter 5), or the Windows-based control software (see chapter 4 and the control software's Help).*



# MGP 462 Multi-Graphic Processor

# A

## **Appendix A**

## **Specifications, Part Numbers, and Accessories**

Specifications

Included Parts

Accessories

# Specifications, Part Numbers, and Accessories

## Specifications

### Video input

Number/signal type .....	4 RGBHV, RGBS, RGsB, RGBcvS, component video, S-video, composite video 1 component video (interlaced), S-video, composite video 1 optional digital component video (SDI, 270 Mbps), S-video, composite video
Connectors .....	4 x 5 female BNC for RGB, component video, S-video, composite video 1 x 3 female BNC for component video, S-video, composite video 1 female BNC for composite video 1 female 4-pin mini DIN for S-video 1 female BNC for optional SDI component video
Nominal level .....	1 Vp-p for Y of component video and S-video, and for composite video 0.7 Vp-p for RGB 0.3 Vp-p for R-Y and B-Y of component video, and for C of S-video
Minimum/maximum levels .....	Analog: 0 V to 2.0 Vp-p with no offset
Impedance .....	75 ohms
Horizontal frequency .....	15 kHz to 100 kHz
Vertical frequency .....	50 Hz to 120 Hz
Resolution range .....	640 x 480 to 1600 x 1200
Return loss .....	<-30 dB @ 5 MHz

### Video processing

Digital sampling .....	24 bit, 8 bits per color; 140 MHz standard
Colors .....	16.78 million

### Video output

Number/signal type .....	1 scaled RGBHV, RGBS, RGsB, or HD component (YUV) video
Connectors .....	1 female 15-pin HD, 5 female BNC
Nominal level .....	1 Vp-p for Y of component video 0.7 Vp-p for RGB 0.3 Vp-p for R-Y and B-Y of component video
Minimum/maximum levels .....	0 V to 1.0 Vp-p
Impedance .....	75 ohms
Vertical frequencies .....	50 Hz, 60 Hz, 72 Hz, 96 Hz, 100 Hz, 120 Hz
Scaled resolution .....	640x480 <sup>1,2,3,4,5,6</sup> , 800x600 <sup>1,2,3,4,5,6</sup> , 852x480 <sup>1,2,3,4,5</sup> , 1024x768 <sup>1,2,3,4</sup> , 1024x852 <sup>1,2,3,4</sup> , 1024x1024 <sup>1,2,3</sup> , 1280x768 <sup>2</sup> , 1280x1024 <sup>1,2</sup> , 1360x768 <sup>2</sup> , 1365x768 <sup>2</sup> , 1365x1024 <sup>2</sup> , 1366x768 <sup>2</sup> , 1400 x 1050 <sup>1,2</sup> , 1600 x 1200 <sup>1,2</sup> HDTV: 480p <sup>2</sup> , 576p <sup>1</sup> , 720p <sup>1,2</sup> , 1080p <sup>1,2</sup> , and 1080i <sup>1,2</sup> <sup>1</sup> = at 50 Hz <sup>2</sup> = at 60 Hz <sup>3</sup> = at 72 Hz <sup>4</sup> = at 96 Hz <sup>5</sup> = 100 Hz <sup>6</sup> = 120 Hz

### Sync

Input type .....	RGBHV, RGBS, RGsB, RGBcvS
Output type .....	RGBHV, RGBS, RGsB Tri-level or bi-level on Y channel of component video
Input standards .....	NTSC 3.58, NTSC 4.43, PAL, SECAM
Input level .....	0.0 V to 5.0 Vp-p
Output level .....	TTL: 5.0 Vp-p, bi-level, unterminated for RGBHV, RGBS, RGsB ±2.5 Vp-p for component video (tri-level sync)
Input impedance .....	510 ohms
Output impedance .....	75 ohms



---

Max input voltage ..... 5.0 Vp-p  
Polarity ..... Positive or negative (selectable)

### Control/remote — processor/decoder/scaler

Serial control port ..... RS-232 or RS-422, 9-pin female D connector  
Baud rate and protocol ..... 9600 baud (default), 8 data bits, 1 stop bit, no parity  
Serial control pin configurations 2 = TX, 3 = RX, 5 = GND  
Ethernet control port ..... 1 RJ-45 female connector  
Ethernet data rate ..... 10/100Base-T, half/full duplex with autodetect  
Ethernet protocol ..... ARP, DHCP, ICMP (ping), TCP/IP, Telnet  
Program control ..... Extron's Simple Instruction Set (SIS™)  
Microsoft® Internet Explorer, Netscape® Navigator®, Telnet

### General

Power ..... 100 VAC to 240 VAC, 50/60 Hz, 30 watts, internal, autoswitchable  
Temperature/humidity ..... Storage -40° to +158°F (-40° to +70°C) / 10% to 90%, noncondensing  
Operating +32° to +122°F (0° to +50°C) / 10% to 90%, noncondensing  
Rack mount ..... Yes, with included brackets  
Enclosure type ..... Metal  
Enclosure dimensions ..... 1.7" H x 17.5" W x 12.0" D (1U high, 1 rack wide)  
4.3 cm H x 44.5 cm W x 30.5 cm D  
(Depth excludes connectors and knobs. Width excludes rack ears.)  
Product weight ..... 6.8 lbs (3.1 kg)  
Shipping weight ..... 11 lbs (5 kg)  
DIM weight, international ..... 12 lbs (6 kg)  
Vibration ..... ISTA 1A in carton (International Safe Transit Association)  
Listings ..... UL, CUL  
Compliances ..... CE, FCC Class A, VCCI, AS/NZS, ICES  
MTBF ..... 30,000 hours  
Warranty ..... 3 years parts and labor

**NOTE** All nominal levels are at  $\pm 10\%$

**NOTE** Specifications are subject to change without notice.

## Specifications, Part Numbers, and Accessories, cont'd

---

### Included Parts

These items are included in each order for an MGP 462:

Included parts	Replacement part number
MGP 462	60-623-01
<i>or</i>	
MGP 462D	60-623-02
MBD 149 rack mounting kit	70-077-03
IEC power cord	27-044-01
Rubber feet (self-adhesive) (4)	
Tweezer (small screwdriver)	
<i>MGP 462 User's Manual</i>	

### Accessories

These items may be ordered separately:

Accessories	Part number
SDI video input card	70-168-02



## MGP 462 Multi-Graphic Processor

# Appendix B

## Installing the SDI Card

Installing a Serial Digital Interface (SDI) Card

# Installing the SDI Card

## Installing a Serial Digital Interface (SDI) Card

The optional SDI input card may be installed in the MGP 462 if the unit does not already have an input for a serial digital interface signal. The following picture shows the MGP 462 with the SDI card installed.

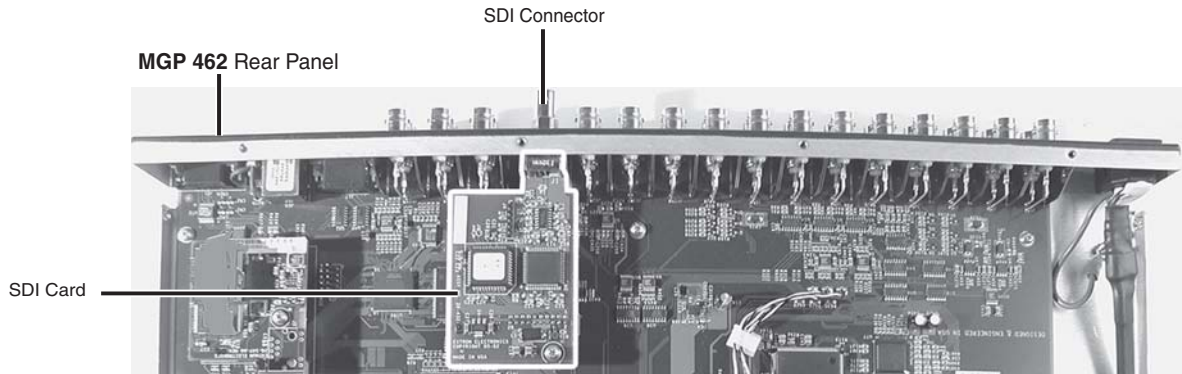

### **MGP main board with SDI input card installed**

**CAUTION** Changes to electronic components must be performed by authorized service personnel only.

Follow these steps to install an SDI input card in the MGP 462:

1. Disconnect the AC power cord from the MGP 462 to remove power.

**WARNING** To prevent electric shock, always unplug the MGP from the AC power source before opening the enclosure.

2. If the MGP is rack mounted, remove it from the rack, and remove the mounting brackets, if they are attached.
3. Remove the cover of the MGP 462 (the top half of the enclosure) by removing the 14 screws on the top and sides, then lifting the cover straight up.

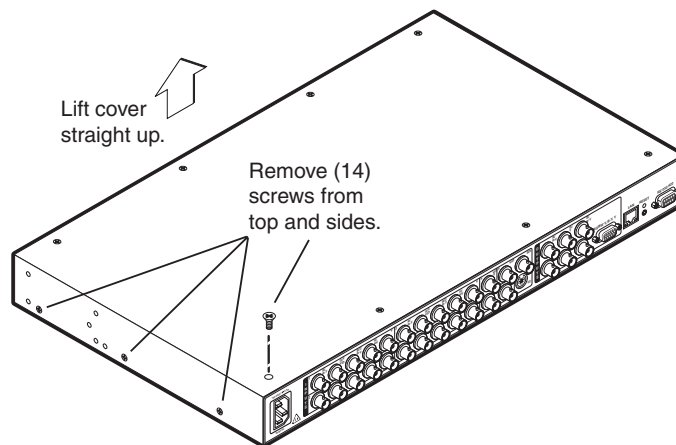

### **Removing the MGP 462 cover**

**CAUTION** Do not touch any switches or other electronic components inside the MGP 462. Doing so could damage the unit. Electrostatic discharge (ESD) can damage IC chips even though you cannot feel it.

You must be electrically grounded before proceeding with any electronic component replacement. A grounding wrist strap is recommended.

4. If the SDI connector opening on the rear panel is still covered, remove the plastic cover from opening.

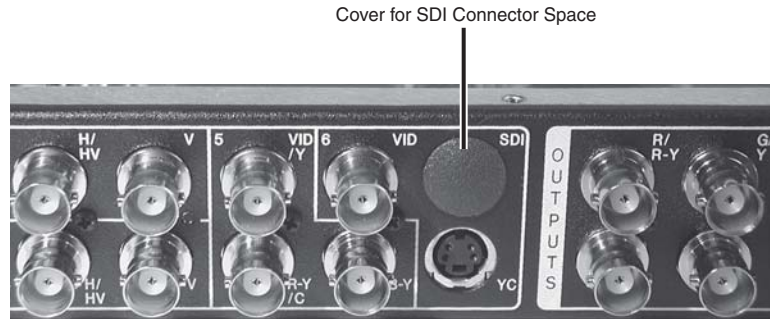

5. Locate the SDI input card standoff near the middle rear portion of the main circuit board (looking from above with the front panel nearest to you). See the following picture.

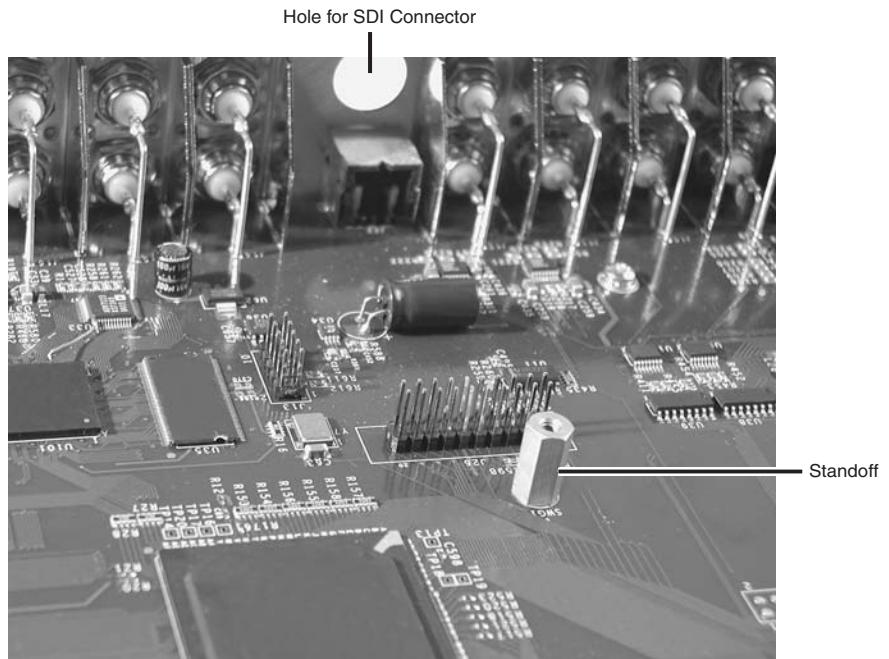

#### **SDI input card standoff**

6. Position the SDI card with its connector protruding through the rear SDI connector opening as far as it will go. Be sure that the side with the chips is facing up.

## Installing the SDI Card, cont'd

---

7. The SDI input card has a 20-pin socket on the underside which must align with the 20 pins on the main circuit board. Be sure to align the pins properly to prevent bending them, before pressing the SDI card down firmly in place onto the standoff. The mounting hole on the SDI card should now be directly over the standoff. See the following picture.

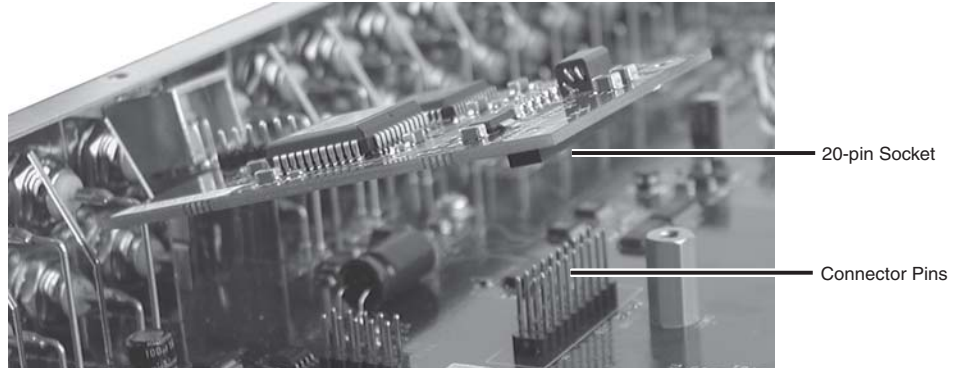

### ***Aligning the 20-pin connector with its socket under the board***

8. Insert the SDI card's installation screw through the card's mounting hole and gently tighten it into the standoff. See the picture below.

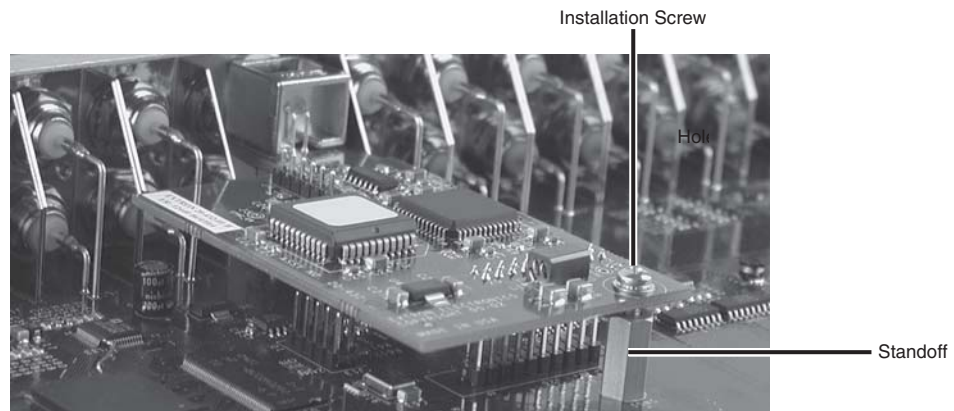

### ***Installed SDI input card***

- 
9. Install the metal hex nut around the SDI connector on the back panel of the unit. Keep the SDI card from twisting as the nut is tightened.

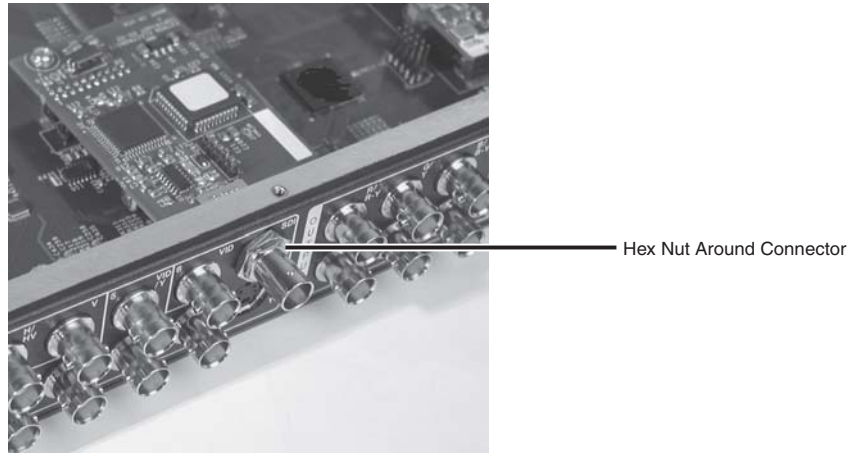

***Hex nut installed around SDI connector***

10. Replace the top cover on the unit, and fasten it with the screws that were removed in step 3.
11. Rack mount the MGP 462, if desired, and reconnect the AC power cord.

## **Installing the SDI Card, cont'd**

---





# MGP 462 Multi-Graphic Processor

# Appendix C

## Firmware Update Guide

Determining the Firmware Version

Downloading the Firmware

Updating the Firmware

# Firmware Update Guide

---

Updates to the Extron MGP 462 Multi-Graphic Processor firmware are made available periodically via the Extron Web site. If the need arises, you can replace the MGP 462's main firmware via an IP connection without opening the unit or changing firmware chips.

## Determining the Firmware Version

You can find out which version of firmware the MGP 462 is using in the following ways: view the front panel LCD window during power-on, view the System Status page of the MGP 462's embedded Web pages, or select About ... from the Help menu in the Windows-based control software.

You can also obtain the firmware version by entering an SIS command. See chapter 4, *Software Configuration and Control*, for the syntax for this command.

## Using the LCD display at power-on

Watch the LCD window as you connect the MGP 462 to a power source. The first piece of information displayed on the screen is the firmware version (along with the product name).

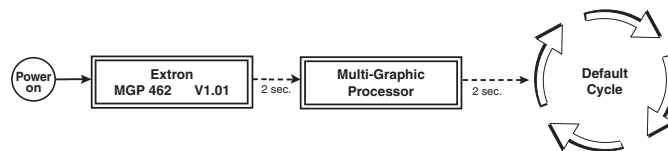

**Power-up cycle flow diagram**

## Using a Web browser

The MGP 462 comes from the factory with a set of default embedded Web pages. The System Status Web page displays the firmware version of your unit, along with other information such as your MGP's IP address and part number. To use the Web pages to find out the current firmware version number, follow these steps:

1. Connect the MGP 462 to a computer via an Ethernet connection (using a crossover cable), or connect the MGP and the computer to a network/LAN (using a straight-through cable). See *Cabling* in chapter 2 for details.
2. Start a Web browser program (such as Microsoft® Internet Explorer).
3. Enter the MGP 462's IP address in the browser's Address field.

**NOTE** *If your local system administrators have not changed the value, use the factory-specified default, 192.168.254.254, for this field.*

4. Press the Enter key. If the MGP 462's HTML pages are not password protected, the browser displays the System Status page.

If the MGP 462's HTML pages are password protected, the browser displays the password prompt window, shown on the next page.



**Example of a password prompt window**

- a. Enter the appropriate administrator password in the Password field.
- NOTE** A User name entry is not required.
- b. If desired, select the check box to have the system input your password the next time you enter your MGP 462's IP address.
  - c. Click OK. The System Status page or your custom start page opens.
5. Select the Status tab to show the System Status page if it is not already displayed. The firmware version is listed in the System Description area, as shown below.

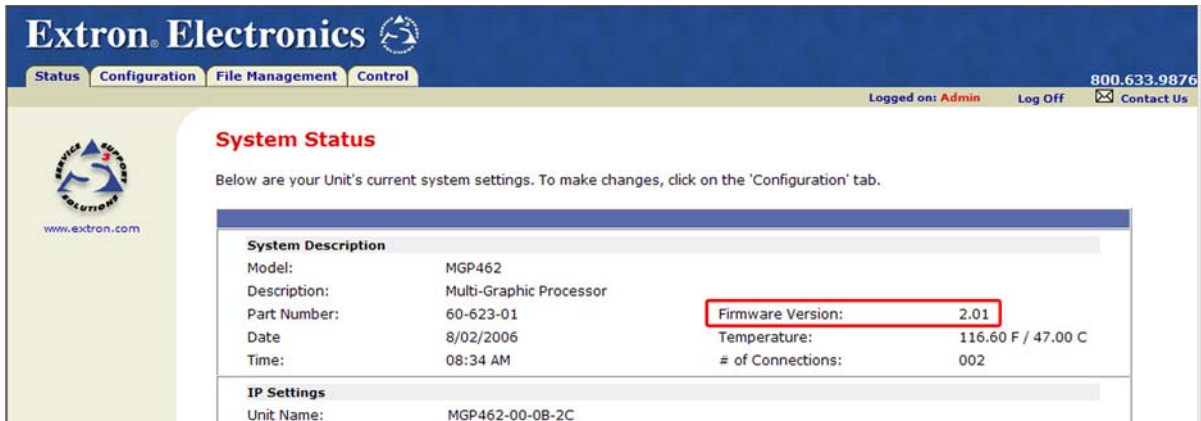

**Firmware version number on the System Status Web page**

**Using the Windows-based control software**

A third way to find out the firmware version is to access the MGP 464 Windows-based configuration software.

1. Open the configuration software. (See *Using the Windows®-based Control Software*, in chapter 4, for the procedure.)
2. From the Help menu, select About... . The following screen appears, providing information about the current MGP version.

## Firmware Update Guide, cont'd

---



### **About MGP screen**

3. When finished viewing the information, click OK to close the window.

## Downloading the Firmware

To obtain the latest version of MGP 462 firmware, follow these steps:

1. Visit the Extron Web site ([www.extron.com](http://www.extron.com)) and go to the MGP 462 page.
2. Click Downloads.
3. On the Downloads page, click the Firmware link, listed under Software and Firmware.
4. On the Download Center page, fill in the required information, then click the Download\_MGP462\_FW2x01.exe button. A File Download - Security Warning window is displayed.
5. Click Save. A Save As window opens.
6. Browse to the folder on your computer where you want to save your firmware file, and click Save. The firmware installation file is placed on your computer disk.
7. When ready to install the new firmware, locate the downloaded file (called MGP462\_FW2x01.exe), and double-click on it to open it.
8. Follow the instructions on the screens to install the new firmware on your computer. A Release Notes file, giving information on what has changed in the new firmware version, and a set of instructions for updating the firmware are also loaded to your computer.

## Updating the Firmware

After you have installed the new firmware on your computer, you must upload it to the MGP 462. Firmware uploads can be performed via a Web browser and the MGP 462's internal Web page or by using the Windows-based control software. The computer and the MGP 462 must both be connected to an Ethernet network in order to update the main firmware. Firmware upgrades can be performed only via an IP connection.

**NOTE** Check the Extron Web site for firmware-related documents, instructions, patch files, and new firmware files before loading new firmware into the unit.

## Updating using the Web pages

Follow these steps to update the firmware using the Web pages:

1. Launch a Web browser (for example, Internet Explorer) on the connected computer, and enter your MGP's IP address in the address field.
2. If no password has been assigned, the MGP 462 Web page opens, displaying the System Status tab.

If an administrator password has been assigned to the MGP, the password prompt dialog box opens (shown below). Enter the administrator password in the Password field (a User name is not required), and click OK. The MGP 462 Web page appears.



### Password prompt window

**NOTE** Passwords must contain 4 to 12 alphanumeric characters. Symbols and spaces are not allowed, and the passwords are case sensitive.

3. On the MGP 462 Web page, select the Configuration tab, then select Firmware Upgrade from the menu on the left of the screen. The Firmware Upgrade screen appears.

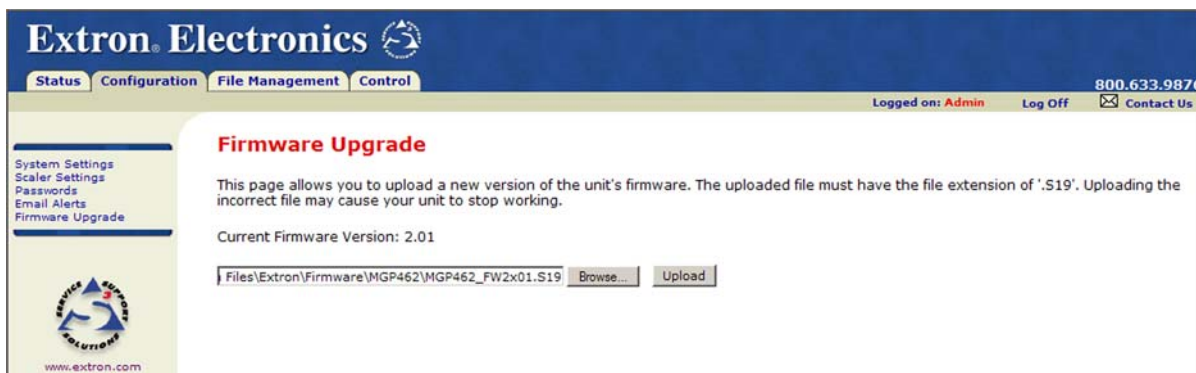

### Firmware Upgrade screen

4. Click the Browse button to open the Choose file window, and locate the firmware file that you downloaded and saved in step 1. **The file extension must be .S19.**

**CAUTION** Uploading a file with an incorrect extension may cause the unit to stop working.

## Firmware Update Guide, cont'd

---

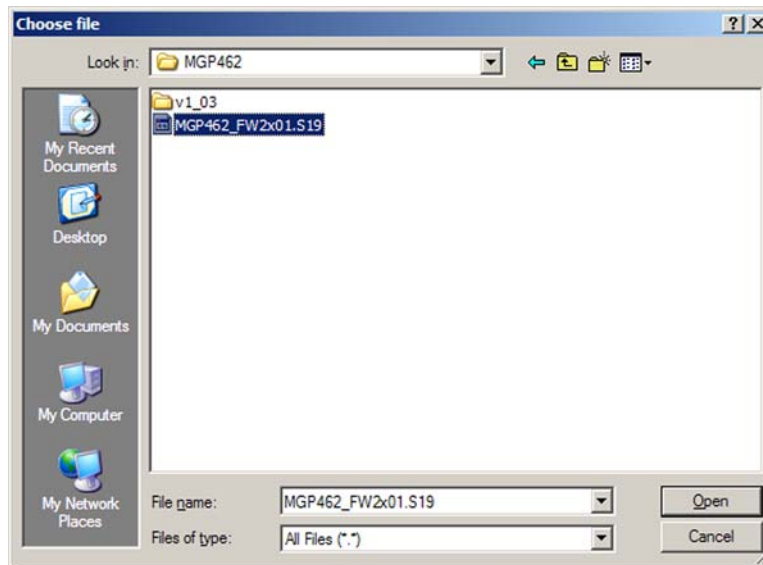

### **Choose File screen with firmware file selected**

5. On the Choose file window, open the firmware file. Its name appears in the field below the Current Firmware Version on the Firmware Upgrade screen.
6. Click the Upload button on the Firmware Update screen to start the firmware update process. While the firmware is being uploaded, the Upload button changes to Uploading...; and the LCD window on the MGP displays first **Firmware Upload Please Wait!!!**, then **Firmware Reboot Please Wait!!!**. While the firmware is uploading and rebooting, do not press any front panel buttons or make any selections on the Web pages.

When the update is complete, the new firmware version number is displayed in the Current Firmware Version field. The LCD screen on the unit displays the first screen that appears on power-up, containing the new firmware version number.

7. If you want to further verify that the new version has been loaded, click the Status tab and view the current firmware version on the System Status screen.

## **Updating using the Windows-based control software**

To update the firmware on the MGP 462 using the Windows-based control software, follow these steps:

1. Open the Windows-based control software. See *Using the Windows®-based Control Software* in chapter 4 for information on accessing this program.
2. From the Options menu, select Update Firmware... . An Open window appears.

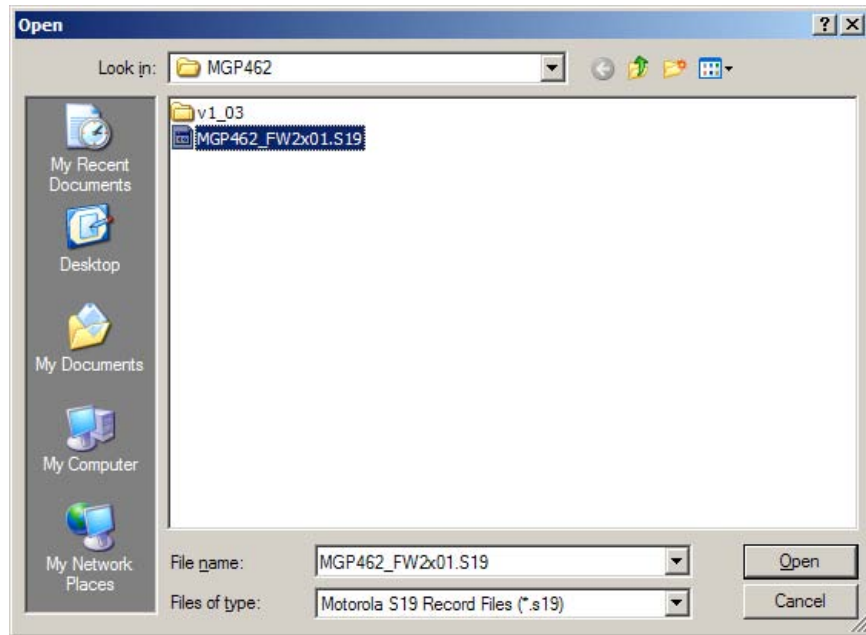

**Open window with firmware file selected**

3. Browse to locate the firmware file that you saved to your computer. **The file extension must be .S19.**

**CAUTION** *Uploading a file with an incorrect extension may cause the unit to stop working.*

4. Double-click on the firmware file icon. The firmware uploading process begins. While the firmware is loading, a progress bar is displayed:



**Firmware update progress bar**

5. When the firmware update is complete, the progress bar closes.

# Firmware Update Guide, cont'd

---



## FCC Class A Notice

Note: This equipment has been tested and found to comply with the limits for a Class A digital device, pursuant to part 15 of the FCC Rules. These limits are designed to provide reasonable protection against harmful interference when the equipment is operated in a commercial environment. This equipment generates, uses and can radiate radio frequency energy and, if not installed and used in accordance with the instruction manual, may cause harmful interference to radio communications. Operation of this equipment in a residential area is likely to cause harmful interference, in which case the user will be required to correct the interference at his own expense.

Note: This unit was tested with shielded cables on the peripheral devices. Shielded cables must be used with the unit to ensure compliance.

## Extron's Warranty

Extron Electronics warrants this product against defects in materials and workmanship for a period of three years from the date of purchase. In the event of malfunction during the warranty period attributable directly to faulty workmanship and/or materials, Extron Electronics will, at its option, repair or replace said products or components, to whatever extent it shall deem necessary to restore said product to proper operating condition, provided that it is returned within the warranty period, with proof of purchase and description of malfunction to:

**USA, Canada, South America,  
and Central America:**

Extron Electronics  
1001 East Ball Road  
Anaheim, CA 92805, USA

**Europe, Africa, and the Middle East:**

Extron Electronics, Europe  
Beeldschermweg 6C  
3821 AH Amersfoort  
The Netherlands

**Asia:**

Extron Electronics, Asia  
135 Joo Seng Road, #04-01  
PM Industrial Bldg.  
Singapore 368363

**Japan:**

Extron Electronics, Japan  
Kyodo Building,  
16 Ichibancho  
Chiyoda-ku, Tokyo 102-0082  
Japan

This Limited Warranty does not apply if the fault has been caused by misuse, improper handling care, electrical or mechanical abuse, abnormal operating conditions or non-Extron authorized modification to the product.

*If it has been determined that the product is defective, please call Extron and ask for an Applications Engineer at (714) 491-1500 (USA), 31.33.453.4040 (Europe), 65.383.4400 (Asia), or 81.3.3511.7655 (Japan) to receive an RA# (Return Authorization number). This will begin the repair process as quickly as possible.*

Units must be returned insured, with shipping charges prepaid. If not insured, you assume the risk of loss or damage during shipment. Returned units must include the serial number and a description of the problem, as well as the name of the person to contact in case there are any questions.

Extron Electronics makes no further warranties either expressed or implied with respect to the product and its quality, performance, merchantability, or fitness for any particular use. In no event will Extron Electronics be liable for direct, indirect, or consequential damages resulting from any defect in this product even if Extron Electronics has been advised of such damage.

Please note that laws vary from state to state and country to country, and that some provisions of this warranty may not apply to you.



**Extron Electronics, USA**  
1230 South Lewis Street  
Anaheim, CA 92805  
USA  
714.491.1500  
Fax 714.491.1517

**Extron Electronics, Europe**  
Beeldschermweg 6C  
3821 AH Amersfoort  
The Netherlands  
+31.33.453.4040  
Fax +31.33.453.4050

**Extron Electronics, Asia**  
135 Joo Seng Road, #04-01  
PM Industrial Building  
Singapore 368363  
+65.6383.4400  
Fax +65.6383.4664

**Extron Electronics, Japan**  
Kyodo Building  
16 Ichibancho  
Chiyoda-ku, Tokyo 102-0082 Japan  
+81.3.3511.7655  
Fax +81.3.3511.7656